

# Packing and packaging of goods to FLSmidth.

Manufacture of packaging  
Stowage of containers

Approved date: 20-06-2012

Created by: JLVE/BBH

Approved by: HENA

## Table of Contents:

	Page:
1.0 General - The 10 most important points.....	4
1.1 Introduction .....	4
1.2 Awareness of this instruction.....	4
1.3 Standards etc.....	5
1.4 How to use this instruction manual .....	5
1.5 Responsibility of the supplier.....	5
1.6 Ownership .....	6
1.7 Factors requiring special attention: .....	6
1.8 Transport definitions .....	6
1.8.1 Mode of transport .....	6
1.9 Packing of goods.....	6
1.9.1 General notes.....	6
1.9.2 Packing of packages involving also collectively packed goods.....	7
1.9.3 Impacts sustained by the goods while in transit .....	7
1.9.4 Positioning and fixation of equipment .....	8
1.9.5 Lifting and securing of goods during transport .....	9
1.9.6 Stiffeners/fastening.....	10
1.9.7 Dangerous goods .....	10
1.9.8 Designations .....	11
1.10 Marking .....	11
1.10.1 Marking of the equipment – TAG.....	12
1.10.2 Marking of packages.....	12
1.10.3 Marking dangerous goods .....	13
1.11 Packing for local transport.....	13
1.12 Packing for air transport .....	13
2 Execution of packaging .....	14
2.1 <i>Flow diagram for packing</i> See next page.....	14
2.2 Configuration and production of packaging.....	16
2.2.1 Closed box, case.....	16
2.2.2 Wooden crate, wood.....	21
2.2.3 Plywood boxes - Packaging for containers .....	26
2.2.4 Full steel frame.....	27
2.2.5 Transport steel frame .....	30
2.2.6 Transport frame for pipes, profiles and similar. ....	31
2.2.7 Unpacked/bottom frame - seaworthy.....	33
2.2.8 Unpacked/bottom frame - container. ....	35
2.2.9 Cable drum .....	36
2.3 Lining, packing and protection .....	38
2.3.1 Lining of closed box and light box .....	38
2.3.2 Dense packing .....	39
2.3.3 Valved packing .....	40
2.3.4 Protection .....	40
2.3.5 Materials for packaging and fillers .....	40
2.4 Electrical equipment.....	41
2.4.1 General notes.....	41
2.4.2 Packaging directions for export packaging A .....	44
2.4.3 Means of transportation and dismantling of equipment.....	45
2.4.4 Packing of electrical equipment and lining of boxes.....	45
2.4.5 Placing equipment in boxes.....	46
3 Stowing of container .....	46
3.1 Container transport, general notes.....	46

---

3.2	Container types .....	46
3.3	Stowing .....	47
3.4	Marking .....	47
3.4.1	Placing of units.....	47
4	Data sheet .....	49
4.1	“Pre-shipment” Inspection .....	49
4.1.1	Procedures for pre-shipment inspections .....	49
4.2	Aluminium foil .....	50
4.3	Desiccant.....	51
4.4	Survey of symbols for handling and storage; .....	52

**Reference is made to the following instruction manuals:**

General workshop instructions	520530
Shipment of goods	70001730-1
Storage of mechanical and electrical equipment on Site	39401-01-4.0

**NOTE!**

The present instruction manual is concerned with the situations which, according to the experience of F. L. Smidth, are the most likely to occur. An exhaustive enumeration of all conceivable situations, which may occur during assembly, operation and maintenance of the machine, cannot be provided.

Consequently, if a situation should arise, the occurrence of which is **not** foreseen in the instruction manual, and which the operator is/or feels unable to handle, it is recommended that F. L. Smidth is contacted without undue delay for advice on appropriate action.

## 1.0 General - The 10 most important points.

- 1 Responsibility - the responsibility for ensuring that packing is done correctly in accordance with the directions outlined in this manual rests solely with the supplier.
- 2 Identifiability - all goods must be marked with tags and be weighed and measured.
- 3 Traceability - all equipment parts must be stated on the packing lists.
- 4 Fixing - all goods must be secured in/on packaging.
- 5 Stacking - all goods must be stackable and able to withstand 1000 kg/m2.\*
- 6 Bracing - all packages must be supported under the lid.
- 7 Marking - all goods must be marked with shipment marking.
- 8 Neutralisation - packages must appear neutral, with no company logo.
- 9 Dangerous goods - must always be packed separately.
- 10 Question – contact mail; [bbh@flsmidth.com](mailto:bbh@flsmidth.com) / [jlve@flsmidth.com](mailto:jlve@flsmidth.com)  
[obi@flsmidth.com](mailto:obi@flsmidth.com) / [hena@flsmidth.com](mailto:hena@flsmidth.com)

\*FLS recommends that the supplier manufacture a block of 1m2 that weights 1000 kg (possibly concrete with lifting eye) to check the quality of the packaging.

### 1.1 Introduction

In this edition of the packing instruction manual, FLSmidth will focus on the following:

- uniform global packaging of FLSmidth's goods
- reducing the number of transport damage
- economic use of packaging
- increased use of container transport.

### 1.2 Awareness of this instruction

In its entirety, this instruction manual is an integral part of the purchase order, and the supplier must ensure that all persons involved in the packaging of goods have read and understand this manual before the packaging of goods begins.

If packaging is done by a sub-supplier, it will also be the responsibility of the supplier to ensure compliance with the directions outlined in this manual.

### 1.3 Standards etc.

Reference by FLSmidth to any International and National Standard does not incur an obligation on FLSmidth to provide any recipient, reader or user of the documentation with samples or copies of the said Standard(s).

Hence, any recipient, reader or user of the documentation is expected – at his own cost – to obtain necessary knowledge of the contents of any of the International Standards referred to herein.

FLSmidth does not undertake any responsibility or liability for injury, damage or losses inflicted upon any recipient, reader or user of FLSmidth documentation or a third party by the failure by any receiver, reader or user of FLSmidth documentation to obtain any necessary knowledge of the contents of any of the International and National Standards referred to herein, nor does FLSmidth waive any right to hold a receiver, reader or user of FLSmidth documentation responsible for any injury, damage or loss inflicted upon FLSmidth as a consequence thereof.

The edition of the standards indicated in any documentation corresponds to the standards valid at the time of publication of the documentation.

### 1.4 How to use this instruction manual

This instruction manual is organised as follows:

#### 1 - General

The main part outlines the overall guidelines and the responsibilities relating to packing and packaging.

#### 2 - Examples

The section containing examples is configured as a guide for selection and execution of packaging, and giving instructions for packing and protection of the goods. The examples are based on the **Table 2.1 Flow diagram for packaging.**

This flow diagram provides an overview of the types of packaging which can be used to pack machine equipment and electrical equipment for, respectively, the general cargo transport and container transport, containing also references to the execution of the individual types, and the possible use of lining and protective padding.

#### 3 - Stowing of container.

This section provides a detailed description of methods used for stowing containers.

#### 4 - Data sheet.

This section contains various data sheets and surveys.

### 1.5 Responsibility of the supplier

The responsibility for ensuring that packing is done correctly **rests solely with the supplier.**

If, in the opinion of the supplier, the packaging suggested and defined by FLSmidth is deemed to be unable to withstand the anticipated impacts and will not provide sufficient protection of the equipment in transit to the final destination, the supplier must get in touch with FLSmidth for the correction of the packaging to extent required.

For all supplies involving subsequent transportation, the equipment must be packed/preserved in manner ensuring that, during a period of minimum

months calculated from the time of notification and/or from a delivery date specifically defined in the purchase order, the shipment must preserve the same qualities visually and functionally as before packing by the supplier.

See **General purchase conditions FLS, point 18.2.**

## **1.6 Ownership**

Unless otherwise specifically defined in the purchase order, the packaging used is the property of FLSmidth and is fully included in the agreed price.

## **1.7 Factors requiring special attention:**

It is very important that the attention of the FLSmidth supplier is directed to the following points in connection with the packing of goods for shipment:

- If the purchase order calls for a "pre-shipment" inspection to be made, it must be possible for FLSmidth and/or an inspection company appointed by our customer or by FLSmidth to make a "Pre-shipment" inspection prior to the final closing of packaging, cf. section 4.1.
- Contact the FLSmidth inspector or the responsible person in the purchasing department if there is any doubt as to packaging procedures.
- FLSmidth is fully entitled to reject incorrect packaging at any time and to demand repackaging of parts at the expense of the supplier.

## **1.8 Transport definitions**

### **1.8.1 Mode of transport**

In the event of absent information, it is the responsibility of the supplier to obtain the relevant data.

Two modes of transport are chiefly used by FLSmidth.

- General cargo transport
- Container transport

Air freight may be used, see 1.12.

Equipment categories being used are:

- Machine equipment
- Electrical equipment (electrical and electronics equipment)

## **1.9 Packing of goods**

### **1.9.1 General notes**

For parts packed for general cargo transport, only the packaging will protect the parts from damage, therefore, this requires seaworthy packaging.

Seaworthy packaging must be capable of withstanding impacts sustained in connection with general cargo transport by ship/lorry/rail, i.e. be stacked at 6-8 metres height and thereby be able to withstand bending/damage of the goods.

As for parts to be packed for container transport, the container will protect them from damage, and, therefore, packaging can be executed so that they are able to withstand these less severe impacts. The goods will be kept in a container throughout, or for the main part of, the transport process.

For all modes of transport, it is essential to ensure that the equipment is packed in a manner allowing it to be stacked on the transport vehicle or in a container subject to a load of minimum 1 t/m<sup>2</sup>.

Also the selected packaging must be able to withstand several reloading operations involving use of cranes and forklift trucks.

The clearance under all packaging must be a minimum 100 mm.

1.9.2 Packing of packages involving also collectively packed goods.

The definition "package" is the designation assigned to a unit. The unit may comprise one item or may comprise several items packed together. When items are packed together, this must always be in relation to the same equipment number as indicated in order.

LINE No.	FLS Equip. No. CU id Cust-Equip No. MFL-SPL No.	PCB No.	Machine Element No.
	431.MD140 040.000 432.MD140	4428058	

Packaging requirements for package:

- package for general cargo transport must as a minimum be ½ m<sup>3</sup>
- package for container transport must as a minimum be ¼ m<sup>3</sup>

**Collective packing of parts:**

Definition:

When parts belonging to two or more orders are included in the same package, this is referred to as collective packing of parts.

Rules:

In this context, special attention must be given to two factors:

- 1) Always use the lowest FLSmidth Purchase Order "PO" number for marking the package. The other PO numbers must not be used for marking of package. (However, all PO numbers must be indicated in the relevant packing list).
- 2) Orders from different departments must not be packed together. The first three digits in equipment number represent the department number.

Example 1:

Equipment No. **321**.RM100 must not be packed together with Equipment No. **431**.KL100.

**The orders may be packed together if the indicated department number is the same.**

Example 2:

Equipment No. **321**.RM100 may be packed together with Equipment No. **321**.FN400.

1.9.3 Impacts sustained by the goods while in transit

The packaging used and the goods contained therein must be capable of withstanding the natural impacts resulting from movements occurring while

in transit, from the point of manufacture to the final project destination. The packaging must be capable of withstanding such impacts whether shipped as general cargo or in containers.

In case of maritime transport, the packaging and goods contained therein will be subjected to the G-forces indicated below:

**The movements of a ship:**

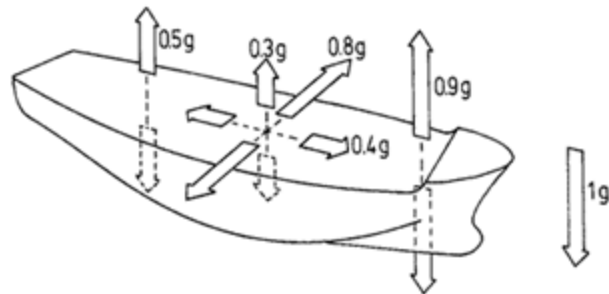

Image 1



Image 2



Image 3



1.9.4 Positioning and fixation of equipment

Damage in transit mainly occurs **as a result of inadequate or incorrect fixation of the equipment inside the packaging.**

Optimisation of packaging is achieved by:

- Securing against up to 30 degrees listing movements.
- ensuring that the centre of gravity is kept as low as possible
- ensuring even load distribution at the bottom of packaging
- ensuring correlated dimensions of equipment and packaging
- ensuring vertical packing of plate parts – if possible
- **ensuring fixation of equipment to the bottom of packaging**



- ensuring that equipment is fixed in the strongest areas of packaging (beams, corners, double boards)
- ensuring that equipment is secured by means of fixed connections (use of bolts, welding, stop blocks to the base frame) see images 4 - 7.

Image 4



Image 5



Image 6



Image 7



Machined surfaces must not be in direct contact with wood. **Apply an intermediary layer, e.g. oil paper between wood and the surface. Paper materials may not be used.**

#### 1.9.5 Lifting and securing of goods during transport

##### **Lifting of goods**

It must be possible to lift and place the goods on the transport vehicle without causing damage to the packaging. This is done by using the designated lifting devices (hooks, lifting eyes etc.) or by making it possible to place lifting tools such as slings and similar means. **If the supplier fits hooks, lifting eyes etc. not specified by FLS on the manufacturing drawings, this is the sole responsibility of the supplier.** It is essential to apply the correct symbols and directions in accordance with DIN 55402, see sub-section 4.4, in order to ensure that the goods can be lifted safely and without any risk of damage to the packaging

##### **Securing of goods**

The specific points where the carrier may secure the goods to ensure proper fixation in transit must be indicated, identifying also the points

which must not be used for securing goods to prevent damage to goods or packaging in transit, see sub-section 4.4.

#### 1.9.6 **Stiffeners/fastening**

Stiffeners are used for several reasons, and, therefore, they are very important in connection with the packing of equipment.

The fitting of stiffeners will reinforce the packaging, enhancing the possibilities of securing the equipment. Also, the stiffeners may act as backstops which will prevent the equipment from being displaced in transit, or they may be fitted to support heavy protruding parts.

So, when stiffeners are used, it is essential to ensure that they have the capability to withstand the stress loads exerted by the equipment and that they are effectively fastened by means of bolts or screws to prevent them from breaking loose while in transit.

**The goods must not, under in any circumstances, be used to strengthen the box, but must always be clear of the sides of box and the box cover.**

If steel sections are used for stiffening purposes, they must be painted according to the paint programme 1a (see instruction No. 520530) or according to the procedures applied for the packed goods.

#### 1.9.7 **Dangerous goods**

Dangerous goods must be packed and shipped in accordance with the relevant sections of:

- |                       |   |
|-----------------------|---|
| <b>ADR 2007</b>       | - <b>International Transport of dangerous goods by road</b>                     |
| <b>RID</b>            | - <b>Carriage of dangerous goods by rail</b>                                    |
| <b>IMDG</b>           | - <b>International Maritime Dangerous Goods</b>                                 |
| <b>ICAO-TI – ICAO</b> | - <b>Technical Instruction for the safe transport of dangerous goods by air</b> |

Examples of dangerous goods:

- Radioactive substances (e.g. in indicating units)
- Flammable, corrosive or toxic substances such as:  
Glue, oil products, acid, bases and paint
- Pressurised gas cylinders

The following information **must** be provided in the packing list. (see the example below).

- Proper Shipping name
- UN No. (UN. NO.)
- Class
- Packing group
- Flame point
- Marine pollutant (answer simply: yes or no)
- The most dangerous ingredient of the substance

FLS PACKING LIST				FLSmidth A/S - Cement Proj. Expediting Department Vigerslev Alle 77 DK-2500 Valby, Denmark		Sh. 26		
Customer: Modern Cement & Mining Co. Ltd. Qatana, Jordan				Purchase Order No./Pckg.No. FLS 4-0845209-310398A / 1-2		Contract Charge No. 08-45209		
Packages	Weight Kilos	Weight Kilos	Dimensions (L x W x H) mm			CBM		
2 Pallet	GROSS	NET	L	W	H			
	745	708	1200	800	880			
Total	1490	1416	1,690 CBM					
Contains dangerous goods. UN No: 1263, Class: 3, Packing Group: III, Flash Point: 25C 77F, Proper Shipping Name: Paint, Marine Pollutant: No, Most Dangerous Components: Colophony, 2-butanone oxime								
Package no 1 packed in container 4-0845209-228267A/10001. Package no 2 packed in container 4-0845209-228267A/10001								
Qty./UOM	Description	Drawing No.	Part List MPL/SPL	Machine Element No.	FLS Equip. No.	Cust. Equip. No.	Weight	
44	PILOT QD PRIMER RED 20L		751.XM100		751.XM100	025.000	1416	
							Total	1416

In connection with shipment of dangerous goods, the Material Safety Data Sheet (MSDS) must always be forwarded together with the packing lists. Also the dangerous goods section must be ticked off "✓" in the packing list that is sent via the FLS WEB PACKING LIST SYSTEM.

Contact FLSmidth LOGISTIC/Expediting (Contact persons; see WEB Manual) or via mail; [iedept@flsmidth.](mailto:iedept@flsmidth.), in case of any doubt concerning the completion of the packing lists.

**Important: Dangerous goods must not be packed together with any other equipment. It must be clearly marked as stipulated above.**

### 1.9.8 Designations

The following designations for packing are used by FLSmidth:

- Closed box, case
- Wooden crate
- Plywood box
- Steel box
- Transport steel frame
- Full steel frame
- Barrel on pallet
- Cable drum
- Bundle
- Pallet
- Unpacked, skid/bottom frame
- closed wooden case
- wooden crate,
- Plywood box
- Steel box
- Transport steel frame
- full steel frame, frame
- barrel on pallet, drum
- cable drum, drum
- bundle
- Pallet
- unpacked, skid/bottom frame

For packing as per designations above, the designation must be used in the packing list and the invoice sent to FLSmidth.

### 1.10 Marking

1.10.0 All wood used in manufacturing/shipment must be supplied with legible stamps as per Standard ISPM 15. **(See image 8)**

Image 8



1.10.1 Marking of the equipment – TAG

Follow the directions given in instruction No. 70001730 (dispatch of goods) according to which all equipment must have a TAG for identification

**Secure TAGS with galvanised wire or UV resistant Plastic Strips/binders manufactured by e.g.**

**PANDUIT**

**HELLERMANN TYTON**

1.10.2 Marking of packages

Follow the directions given in *instruction No. 70001730* (shipment of goods).

Mark the packing with symbols, such as safety markings, sling chain, gravitation mark etc. as per DIN 55402, see sub-section 4.4.

"Gravitation marks" must also be painted to indicate the centre of gravity if the centre of gravity is displaced in relation to the centre. (see image 9 and field F, section 4.4)

Image 9



Goods that must not be exposed to water/rain must always be marked with the ISO symbol "Keep dry" (see image 10 and section 4.4).

Image 10



ALL packaging to be marked with "This side up" and "chains"/"lifting directions". (see image 11 and section 4.4)

Image 11



**Handling symbols must be applied to a minimum of 2 sides.**

#### 1.10.3 Marking dangerous goods

Dangerous goods must always be marked in accordance with international regulations, see sub-section 1.9.7.

### 1.11 Packing for local transport

Local transport is taken to mean **road transport over a short distance** which does not involve reloading of goods, i.e. loading of goods at the supplier's premises and delivery to plant site or the packaging contractor.

Unless otherwise agreed, **it is the responsibility of the supplier to determine** what constitutes responsible packaging, giving due consideration to:

- Protection of the goods (including sensitive components, painted surfaces)
- Risk of damage in transit (level of fixation, damage resulting e.g. from a collision)

### 1.12 Packing for air transport

The procedures for packing goods for air transport are as follows:

1. When air freight is the preferred mode of transportation, the lightest and smallest type of packaging must be selected, so that due account is taken of the weight and volume of goods involved. At the same time it must be ensured that the goods are adequately packed to withstand air transport. Reference is also made to packing in light boxes, sub-section 2.2.3.
2. All sharp edges and corners must be covered/protected to prevent them from causing damage to other goods in aircraft or aircraft equipment. Unpacked goods or bundles may also be accepted for air freight provided that all sharp edges, including ends of e.g. tubes and/or beams, are also covered and if the goods are securely fastened to ensure immobility.
3. If goods are delivered on pallets, bottom or in a frame, it must be securely fastened to prevent it from moving or being displaced when subjected to turbulence during take-off and touch-down. The aircraft may also be subject to turbulence during the flight, and, in this context,

it is essential to ensure that the goods are thoroughly secured/fixed in the box or on the bottom/pallet to ensure immobility. It must be possible to lift the goods using a forklift truck and the goods must be stackable.

4. If goods arrive at an airport terminal without meeting the aforementioned criteria, the goods will be rejected and the necessary rectifications will be carried out by airport personnel **for the account of the supplier.**

## **2 Execution of packaging**

### **2.1 *Flow diagram for packing***

**See next page**

## 2.1 Flow Diagram for Packing

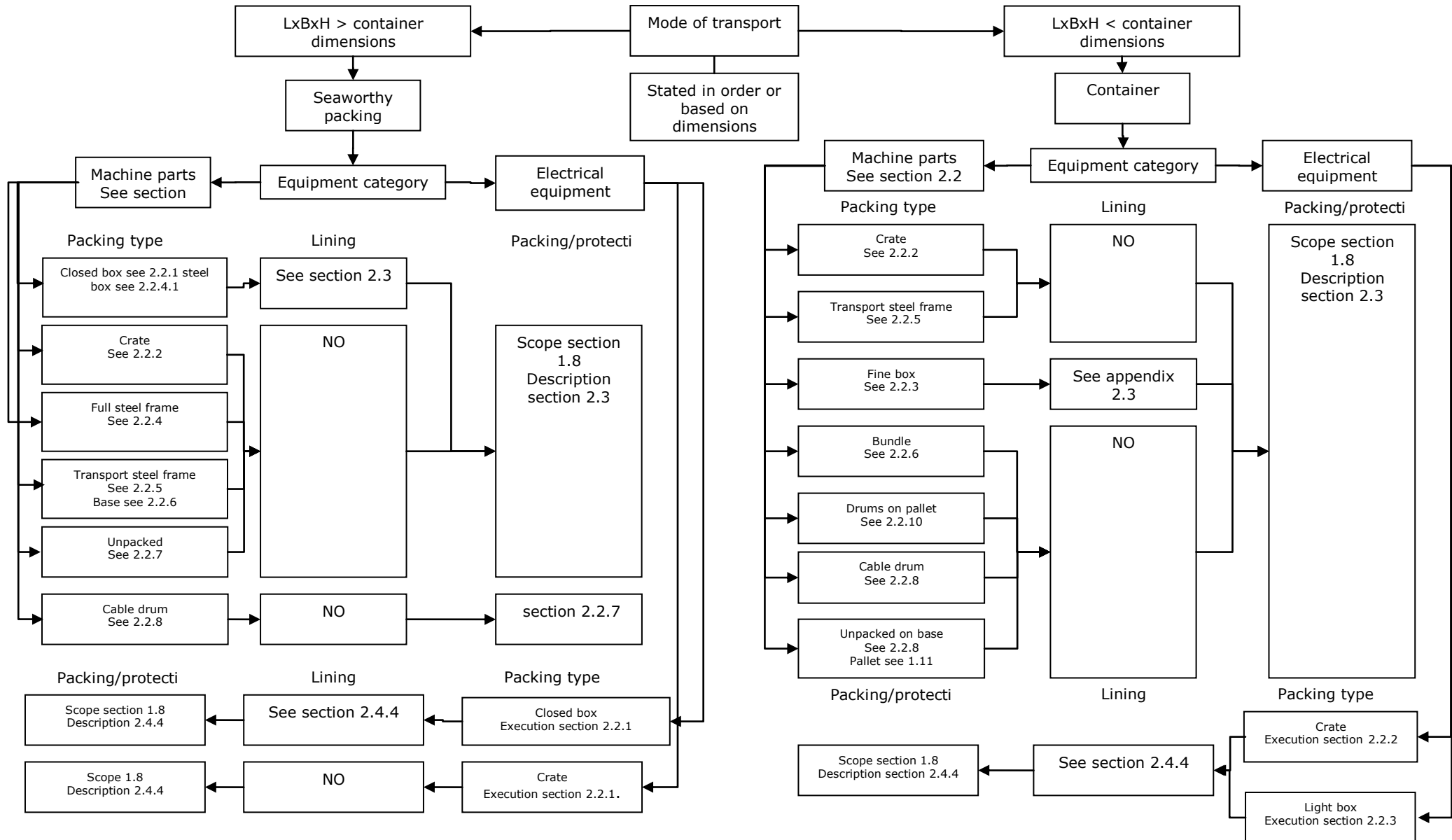



## 2.2 Configuration and production of packaging

### 2.2.1 Closed box, case

There are 3 types of boxes.

1. Type 1; 0 - 2000 kg (See ill. 1)
2. Type 2; 2001 - 3000 kg (See ill. 2)
3. Type 3; 3001 - kg (See ill. 3)

The 3 types are identically configured, except for the design of the bottom and the material thickness.

Read the information below;

#### **Method:**

1. Determine the weight, length, breadth and height of the equipment (weight indication is required in the packing list)
2. Determine whether the equipment is subjected to point loads or evenly distributed loads at the bottom of packaging.
3. Determine whether the equipment is top-heavy (centre of gravity is over centre) or displaced in relation to the Centre. The box must be marked. (see 4.4 F).
4. Use the table (see 2.2.1.1) to select the correct material dimensions.
5. Make the box as per directions (see 2.2.1.1), based on the assessments as per items 1-4.
6. Protect exposed parts/surfaces/sharp edges (if necessary, dismantle projecting parts) There must be no direct contact between machined surfaces and wood. Apply a coated oil film in between.
7. Equip the box with a lining. (see 2.3.1)
8. Place the equipment in the box and **secure** it at the strongest points at the bottom of packaging. (see 1.9.6)



**0 – 2000 KG**

Illustration 1 shows:

A closed box for goods up to 2000 kilos. Dimensions and execution (see 2.2.1.1).

Position of point of gravity (TP) varies considerably according to equipment. After the final position has been determined and indicated, the distances x and y must be identified.

x is the smallest distance from the side of the packaging to TP.

y is the distance from the underside of the bearers to TP.

**For electrical equipment, one shock indicator and 2 tilt indicators must be fitted if ratio:  $y/x > 2$ .**

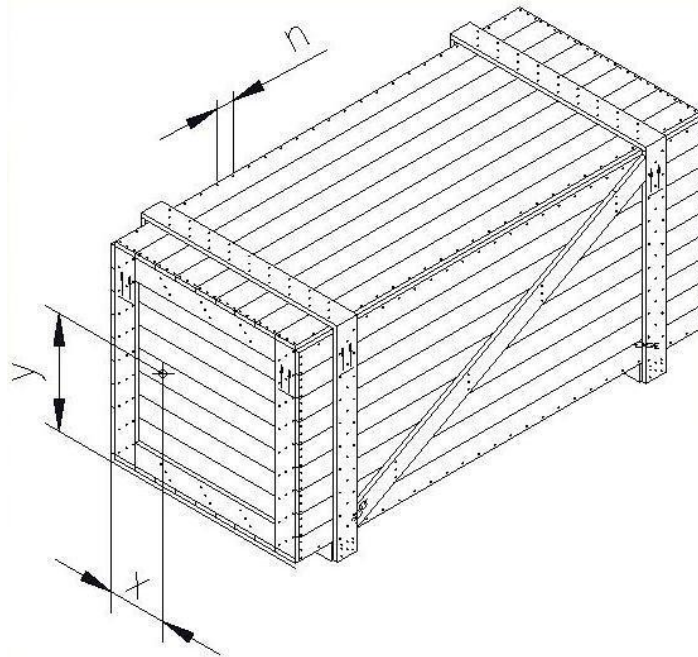

**0-2000 KG.**

**Illustration no. 1**

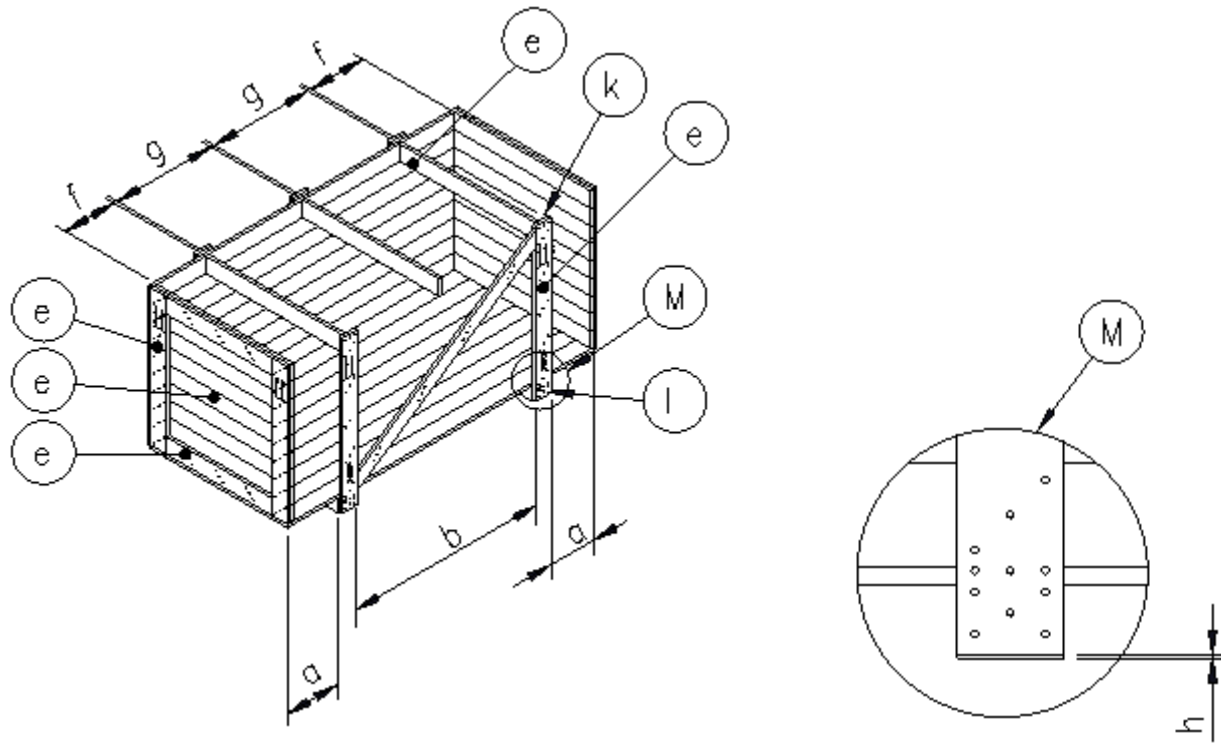

**2001 – 3000 kg**  
**Illustration no.2**

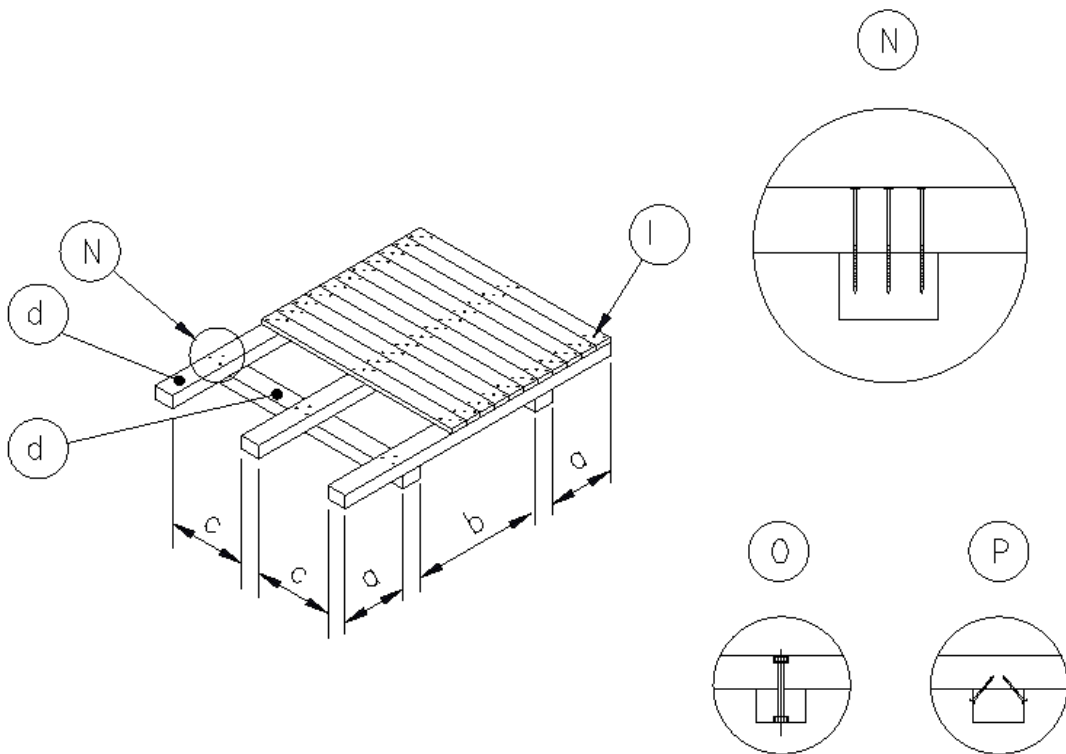

**3001 - > kg**  
**Illustration no. 3**

2.2.1.1.

Dimensions of closed box									Nail length		
Weight [kg]	a max [mm]	b max [mm]	c max [mm]	d [mm]	e [mm]	f max [mm]	g max [mm]	h [mm]	k [mm]	l [mm]	N [mm]
0 - 2000	500	1000		100 x 150	25 x 125	400	800	5	50	75	100
2001 - 3000	500	1000	600	100 x 150	32 x 125	400	800	5	50	75	100
>3000	500	1000	600	100 x 150	38 x 125	400	800	5	75	90	160

O, P (see illustration 3): Preferred assemblies, which state bolt assembly (M12), alternative assembly with French screws (image 12) or shorter nails, min 100 mm.

Diagonal brace: Used on all boxes over 2000 kilos or length over 5 metres.

On boxes with a breadth under 1600 mm, cross braces under the lid are omitted.

Nail: Only use cross threaded steel nails. (see section 2.3.5, and image 12)

Image 12



Examples:

Image 13



The image shows: A closed box 0-2000 kg. Seen from the side

Image 14



The end of a closed box

Image 15



End of the box with additional stiffening elements

Image 16



Image shows: Boxes over 2000 kg with an angle bracket.

### 2.2.2 Wooden crate, wood

Crates can be used for seaworthy and container transport. The only difference for crate used for containers is that the distance between the slots is greater.

- In marine transport, the distance between the slots is 1 x width of the board.
- In container transport, the distance between the slots is 2 x width of the board.

There are 3 types of crates.

1. Type 1; 0 - 2000 kg (See ill. 1)
2. Type 2; 2001 - 3000 kg (See ill. 2)
3. Type 3; 3001 - kg (See ill. 3)

The 3 types are identically configured, except for the design of the bottom and the material thickness.

#### **Read below before executing boxes.**

Method:

1. Determine the weight, length, breadth and height of the equipment.  
(weight indication is required in the packing list)
2. Determine whether the equipment has a point and evenly distributed load at the bottom of packaging.
3. When using Types 2 and 3, an angle bracket must be used as reinforcement for bars and cross braces.
4. Use the table (see 2.2.1.1) to select the correct material dimensions.
5. Protect exposed parts/surfaces/sharp edges  
(if necessary, dismantle projecting parts) Use coated oil film between machined surfaces and wood.
6. Place the equipment in the box and **secure** this.
7. For boxes with a width over 1600 mm cross braces under the lid must be used and secured to the base. As a minimum, the cross braces must have the same dimension as the wood used in the box (see table 2.2.2.1 e)



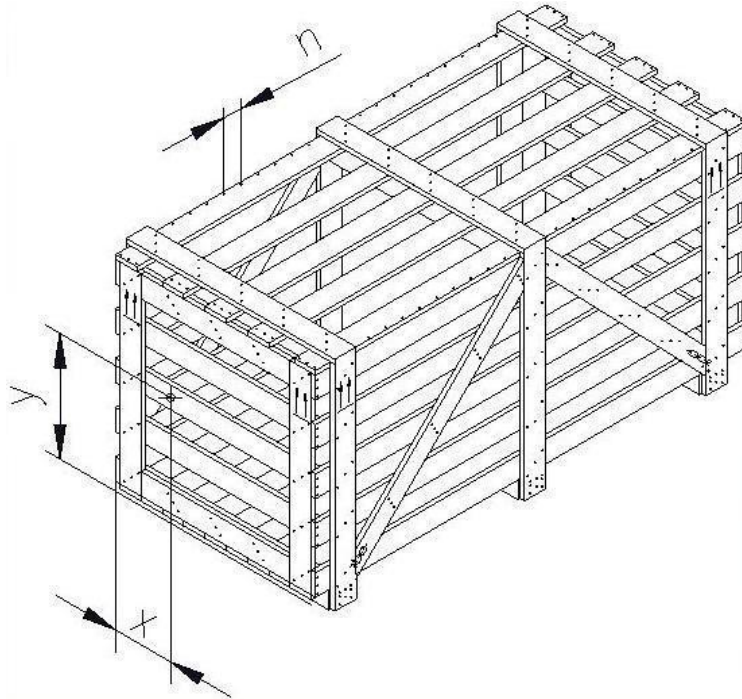

**0-2000 KG**

**Illustration no. 4**

A crate for goods up to 2000 kg. Dimensions and execution (see 2.2.2.1).

Position of point of gravity (TP) varies considerably according to equipment. After the final position has been determined and indicated, the distances x and y must be identified.

x is the smallest distance from the side of the packaging to TP.

y is the distance from the underside of the bearers to TP.

For electrical equipment, one shock indicator and 2 tilt indicators must be fitted if ratio:  $y / x > 2$ .

### Illustrations and dimensions

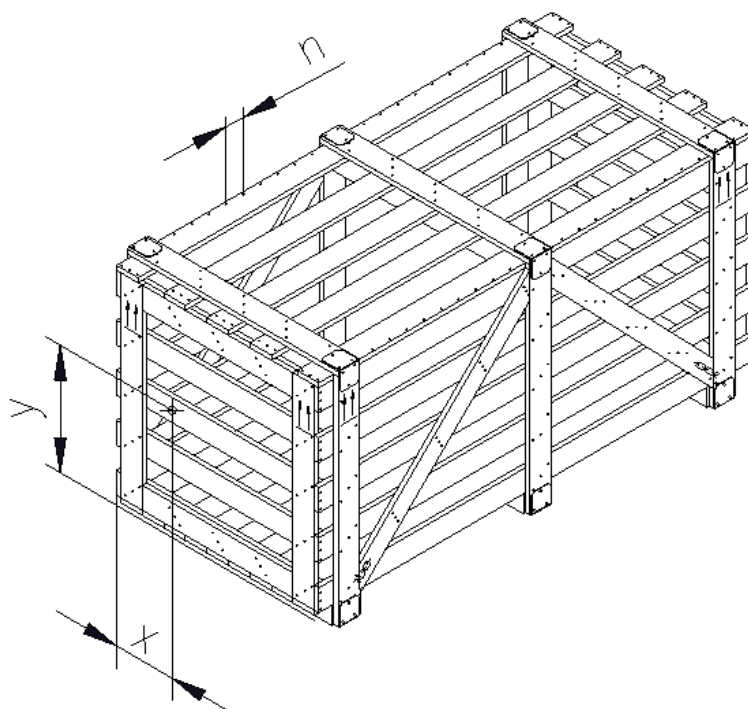
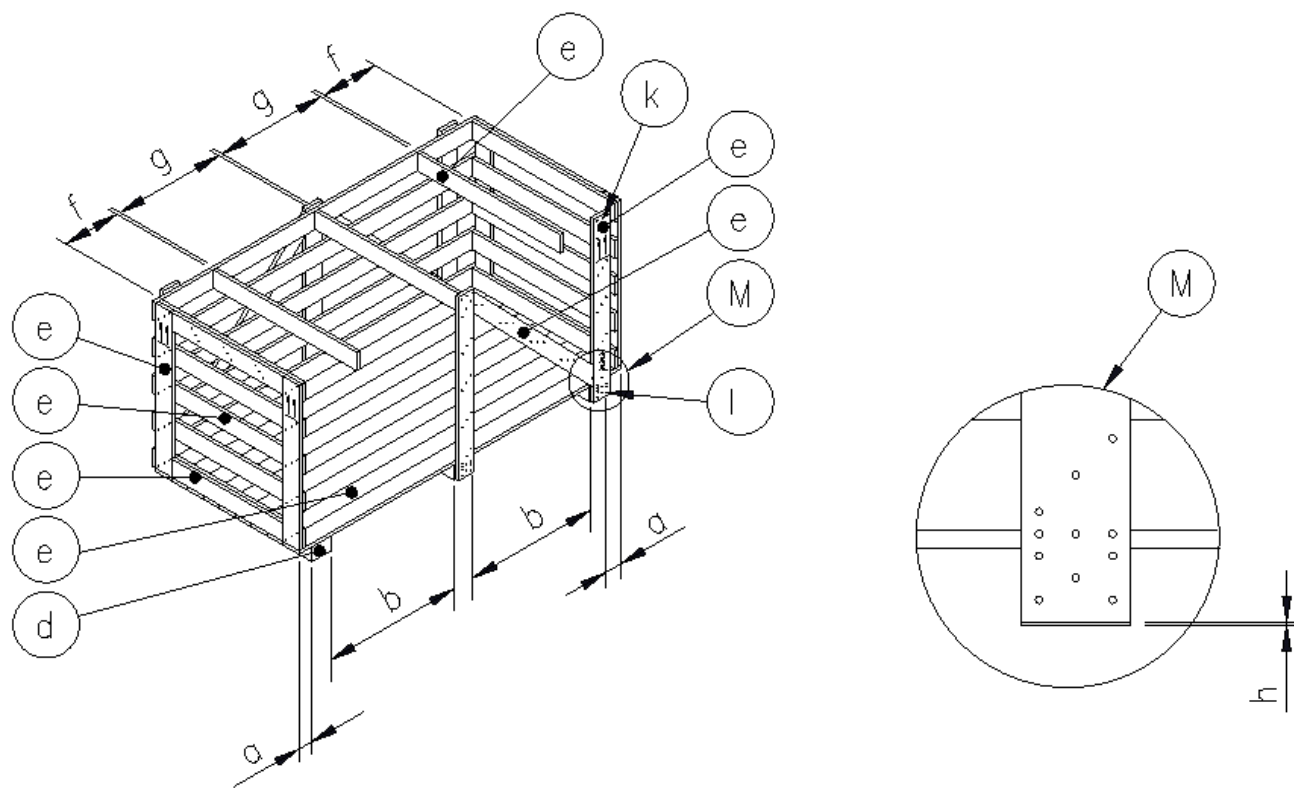

**2001 – 3000 kg**  
**Illustration no. 5**

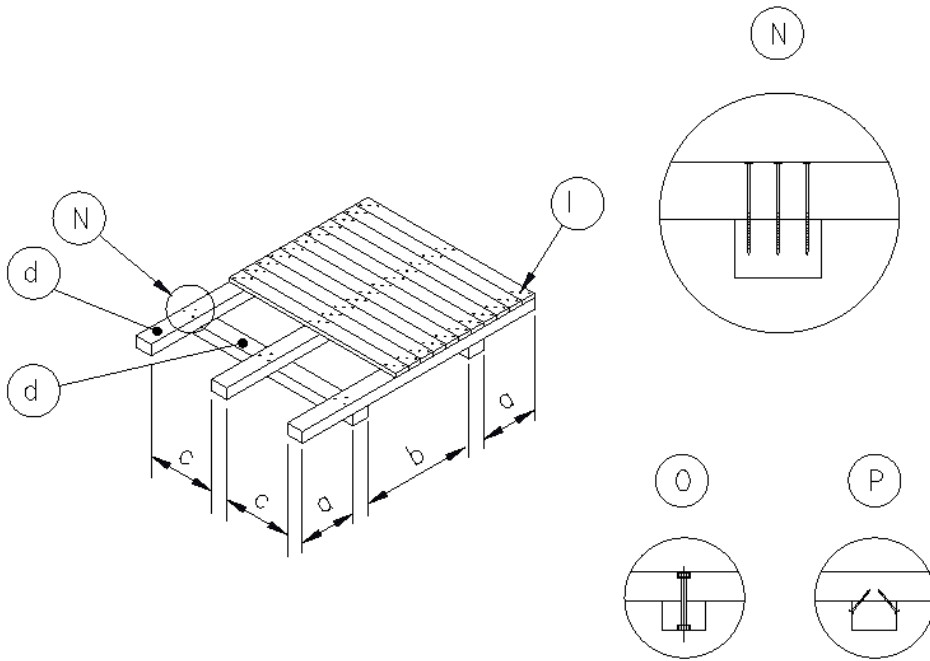

**3001 - > kg**  
**Illustration no. 6**

2.2.2.1

Configuring crates									Nail length		
Weight [kg]	a max [mm]	b max [mm]	c max [mm]	d [mm]	e [mm]	f max [mm]	g max [mm]	h [mm]	k [mm]	l [m m]	N [m m]
0 - 2000	500	1000		100 x 150	25 x 125	400	800	5	50	75	100
2001 - 3000	500	1000	600	100 x 150	32 x 125	400	800	5	50	75	160
>3000	500	1000	600	100 x 150	38 x 150	400	800	5	75	90	160

O, P: Preferred assemblies, which state bolt assembly (M10) or assembly with French screws (image 12) or shorter nails, min 100 mm in 45 degrees.

Diagonal brace: Used on all boxes over 2000 kilos or length over 5 metres.

Nails: Only use cross threaded steel nails. (see section 2.3.5)

For crates with a breadth under 1600 mm, cross braces under the lid may be omitted.

When cross braces are used they must be secured to the base. (see 2.2.2 point 7 and image 17 below)

Image 17

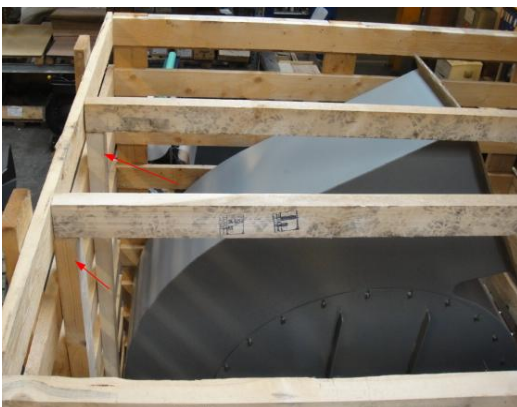



Image 18



A crate for marine transport.



Image 19

Method used for nailing corner joints when assembling the box. Through the side board, there is a row of 3 nails for tacking the vertical end board and a row of 2 nails for tacking at the end of the horizontal end board.



Image 20

A container crate.

As is apparent, the distance between slots has been increased.

2.2.3 Plywood boxes - Packaging for containers

This type of packing can only be used for containers. It should mainly be used for packing of smaller parts, **which can be secured to the crate.**

Standard boxes can be used, with appertaining bottom plate, frames and cover (see table below) or specially adapted boxes can be fabricated, corresponding to the standard boxes. Max weight 300 kg total including tare weight.

The boxes may also be manufactured from steel. **Remember holes/ventilation in the base.**

Standard boxes

<b>Incl. 4 way pallet with dispersed cover, 6 mm plywood</b>			
		Length x breadth x height	Length x breadth x height
Type	Weight [kg]	Dev. Target [mm]	Int. Target [mm]
EU6	32,4	1200 x 800 x 725	1185 x 785 x 570
EU8	35,5	1200 x 800 x 930	1185 x 785 x 775
EU12	41.7	1200 x 800 x 1300	1185 x 785 x 1180
EU6/2	16,3	800 x 600 x 725	785 x 585 x 570
EU8/2	18,4	800 x 600 x 930	785 x 585 x 775

Image 21



Image 22

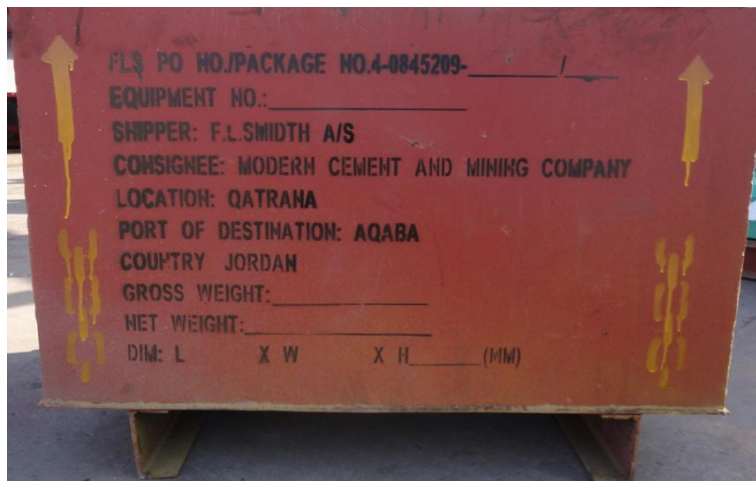

#### 2.2.4 Full steel frame

A full steel frame is taken to mean a frame where all equipment is kept within the frame. The full steel frame is an alternative to the crate. The steel frame can advantageously be used to transport heavy equipment or bulky equipment.

##### Method

1. Determine the weight, length, breadth and height of the equipment. (weight indication is required in the packing list)
2. Ensure that the equipment has a point and evenly distributed load at the bottom of the frame.
3. Place the support for packaging at appropriate locations, and if necessary provide reinforcement of stress-loaded zones.
4. Make the frame, using the illustrations below as a basis, in accordance with the assessments as per items 1-4.
5. Frames to be blast cleaned to Sa2½ according to ISO 8501-1 and painted with 80 µm Epoxy Zink Phosphate (Sigma SF205). Colour Red Brown. The general conditions for pretreatment and painting according to General Workshop Instruction 520530 applies.
6. Protect exposed parts/surfaces/sharp edges/motor/gear.
7. Place the equipment in the frame and secure it.

**Illustration no. 7**

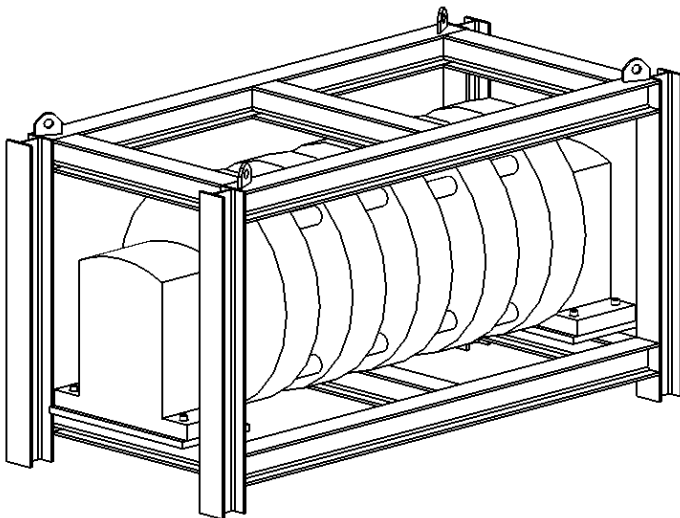
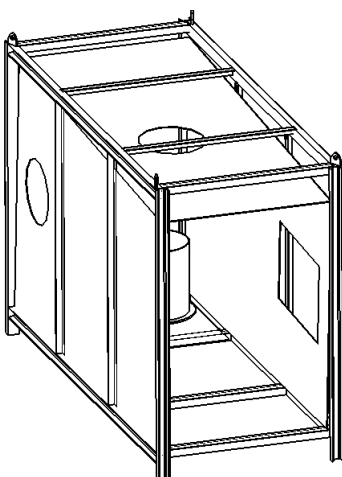

Illustration shows a heavy machine part in a full steel frame. The frame must be made so that it can withstand the loads exerted by overlying parts, up to 1000 kg/m<sup>2</sup>. This frame is made from HEB 100 sections, but the type and dimensions of sections depend on the dimensions and weight of the goods.

**Illustration no. 8**



The illustrations show a light plate construction in a full steel frame. The entire bent-up plate construction is kept within the frame. Here, the outer and bottom frame are made from UNP 65 sections and the centre stiffenings are made of 40 x 40 angle irons. The two loose connectors are fixed to a plate at the bottom of the frame. **For maritime use, the frame must be made so that it will be able to withstand loads exerted by overlying parts, up to 1000 kg/m<sup>2</sup>.**

This frame is an alternative to the crate.

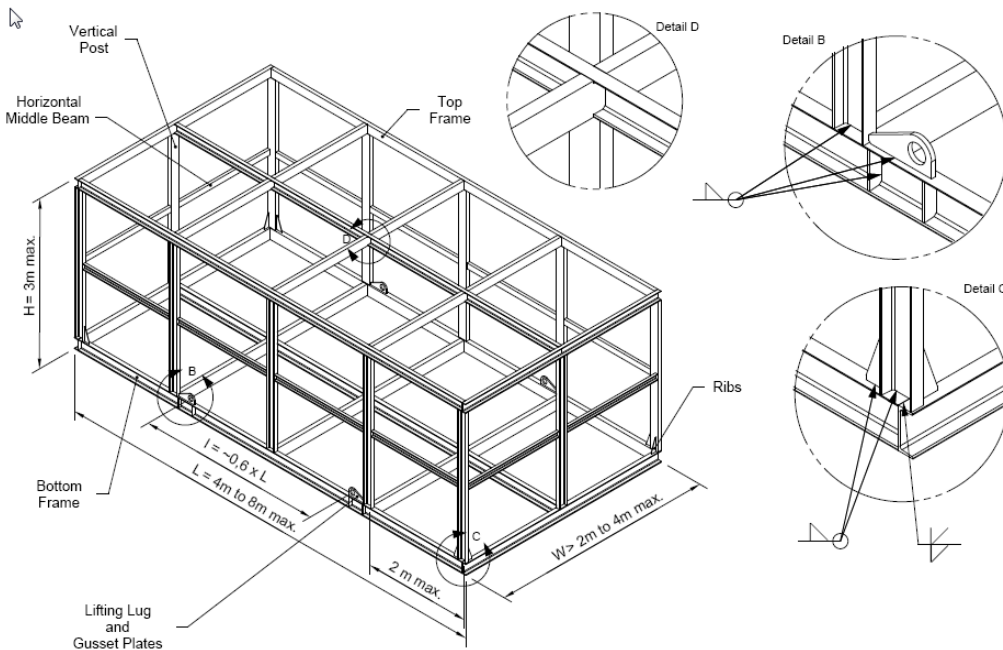
**Illustration no. 9**

In order to choose the correct dimension of the steel frame, use the spreadsheet "calculation for packing" and follow the stages below:

1. Choose type/structure (e.g. 21a)
2. Enter dimensions (follow link [http://packinglist.flsmidth.com/calculation for packing.xls](http://packinglist.flsmidth.com/calculation%20for%20packing.xls) )
3. Enter weight (follow link [http://packinglist.flsmidth.com/calculation for packing.xls](http://packinglist.flsmidth.com/calculation%20for%20packing.xls) )
4. Choose profile stated in the link (ISMC/UNP/V)
5. Manufacture the frame as per the above drawing. Welds as per 520530, QA.

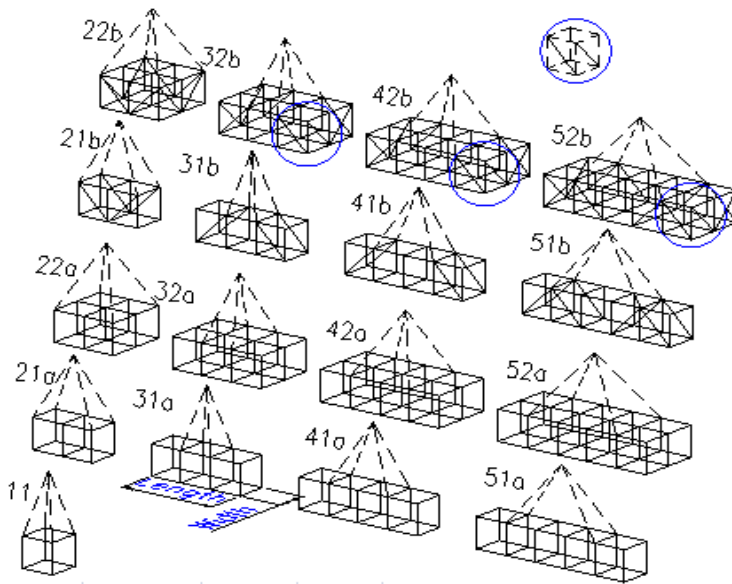

The above diagrams/calculations are intended as a guideline and other designs may occur. It is the responsibility of the supplier to ensure that packaging is correctly executed. The above calculations presume are an evenly distributed load on the steel frame.

Link to the calculation form [http://packinglist.flsmidth.com/calculation for packing.xls](http://packinglist.flsmidth.com/calculation%20for%20packing.xls) " calculation for packing" see <http://packinglist.flsmidth.com>)



Image 23



Image 24



Image 25



#### 2.2.4.1

##### Steel box

Can be manufactured as stated in 2.2.4 with closed steel sides.

**Remember** ventilation/holes in the base.

### 2.2.5 Transport steel frame

#### General notes

A transport steel frame is taken to mean a frame which supports the equipment, but where the equipment is not protected by the frame. The main purpose of the frame is to ensure handling capability and to permit loose parts (see 1.9.2) to be assembled into larger units.

#### Method

When assembling parts:

1. Assemble parts into compact units. (see 1.9.2).
2. Assess the strength of the parts before they are assembled and packed. (pack plate parts vertically if possible).
3. Determine the weight and dimensions of the parts, total length, breadth and height. (Weights to be used in packing list).
4. Determine the position of the overall point of gravity, and assess need for support and fixation.
5. Frames to be blast cleaned to Sa2½ according to ISO 8501-1 and painted with 80 µm Epoxy Zink Phosphate (Sigma SF205). Colour Red Brown. The general conditions for pretreatment and painting according to General Workshop Instruction 520530 applies.
6. Paint the sling attachments **yellow**.

For individual parts:

1. Determine whether it will be possible to minimize the basic area and to optimize height.
2. Determine the position of point of gravity.
3. Manufacture Frames to be blast cleaned to Sa2½ according to ISO 8501-1 and painted with 80 µm Epoxy Zink Phosphate (Sigma SF205). Colour Red Brown. The general conditions for pretreatment and painting according to General Workshop Instruction 520530 applies.
4. Paint the sling attachments **yellow**.

#### Illustration no. 10

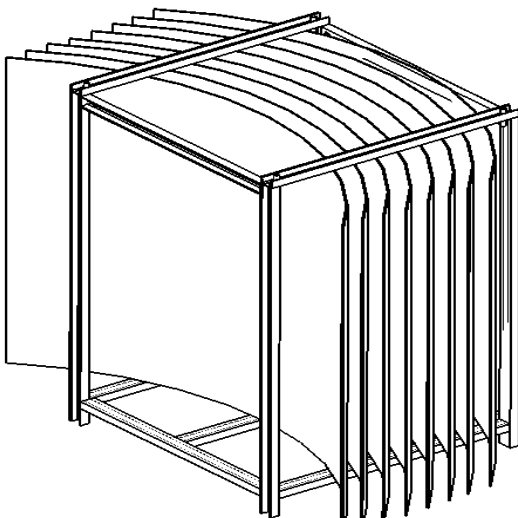

Illustrations no. 10 and 11 show collectively packed plate parts in a transport steel frame fabricated from UNP 65 sections.

The plates are collectively packed in vertical position to avoid deformation of the single plates. Lifting eyes can be welded to the frame or holes can be drilled in the sections, for lifting by crane.

**Illustration no. 11**

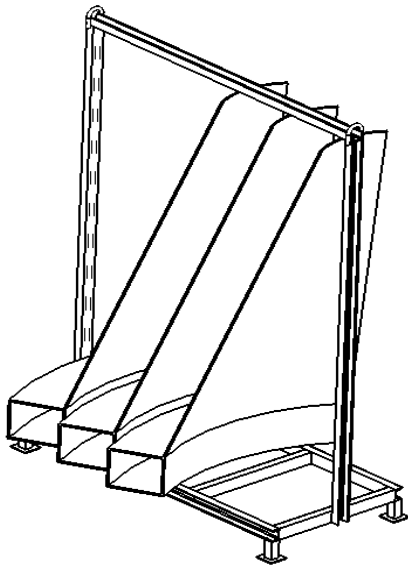

2.2.6 Transport frame for pipes, profiles and similar.

A transport frame is taken to mean a frame which is capable of maintaining the bundle as one unit, while simultaneously allowing handling capability by means of a truck and crane. It is very important to avoid deflections causing damage to the parts or permanent changes or preventing the parts from being lifted by means of a crane or forklift truck.

**Method**

1. Determine the weight and dimensions of the bundle, weight, length, breadth, height, material thickness and type of section.  
(weight indication is required in the packing list)
2. In the table, select the correct material dimensions.
3. Make the frame in accordance with the illustrations below.
4. Paint the sling attachments yellow.
5. Place the bundle in the frame in manner ensuring equilibrium and fix the bundle to the frame.

When using an intermediate layer, use a material that is resistant to moisture and temperature fluctuations (e.g. rubber).

Wood must NOT be used.

**It is recommended that bases be fixed with a steel band.**

6. After fastening, the nuts must be locked by means of counter nuts or by welding to prevent them from working loose in transit.

**Illustrations no. 12**

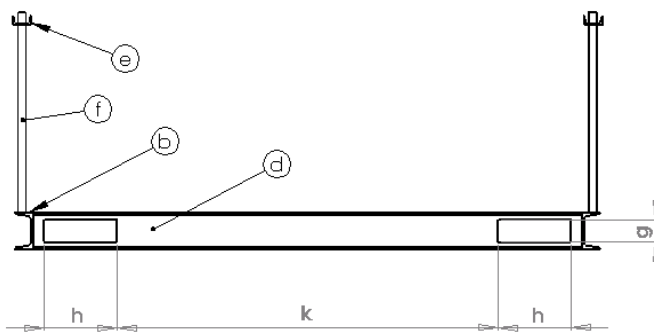
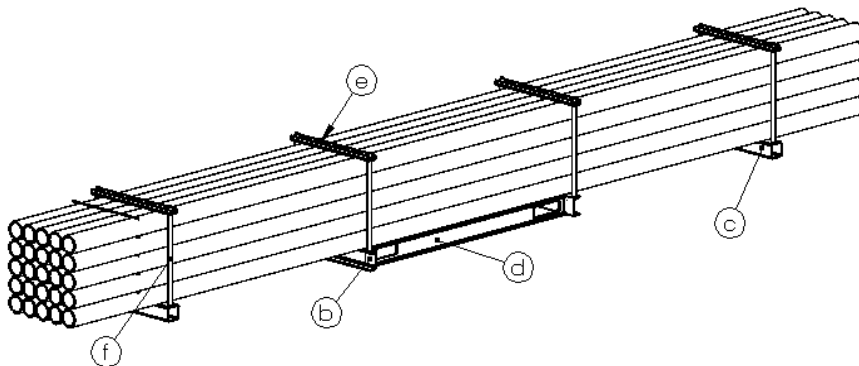

The length of the IPE 100 profile "d" is stated in the table under "a" and is for guidance purposes. Tubes must not be bent.

Length [m]	a [m]	B	C	d	e	f	g [mm]	h [mm]	k [mm]
3 - 7	2	UNP 100	100 x 100 x 4	IPE 100	UNP 65	M 20	60	200	1300
7 - 12	5	UNP 100	100 x 100 x 4	IPE 100	UNP 65	M 20	60	200	1300
>12	7	UNP 100	100 x 100 x 4	IPE 100	UNP 65	M 20	60	200	1300

Alternatively the packaging form below can be used.

Image 26





### 2.2.7 Unpacked/bottom frame - seaworthy

A distinction is made between unpacked in container (see 2.2.8) and unpacked for maritime transport since the container will provide some protection of the equipment and because of different methods for handling of goods.

#### Unpacked - maritime transport

Flow sheet 2.1 stated that goods may be sent unpacked, however this is not recommended. Situations may arise where there only appropriate shipment will be unpacked.

The supplier must protect exposed areas where possible in order to ensure the goods are not damage during transport.

Illustration no. 13

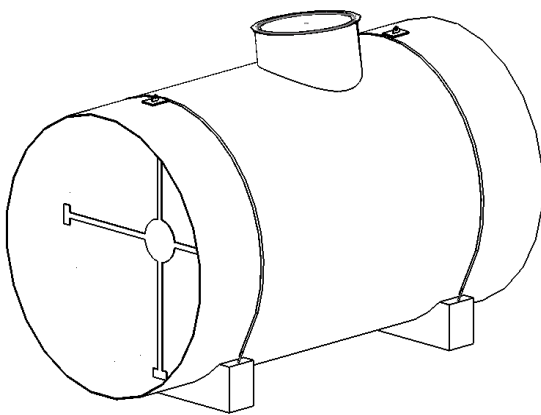

The illustration shows:

Tube section  $\varnothing 4000 \times 10 \times 7000$  mm.

The tube is placed on two cradles, being fixed with flat steel retaining bands.

The tube is also equipped with 2 stiffening crosses to be blast cleaned to Sa2½ according to ISO 8501-1 and painted with 80  $\mu\text{m}$  Epoxy Zink Phosphate (Sigma SF205). Colour Red Brown. The general conditions for pretreatment and painting according to General Workshop Instruction 520530 applies

Image 27



Image 28



Images 29, 30 and 31 show examples of the protection of teeth on a sprocket wheel.

In image 29 tectyl and oil paper are added

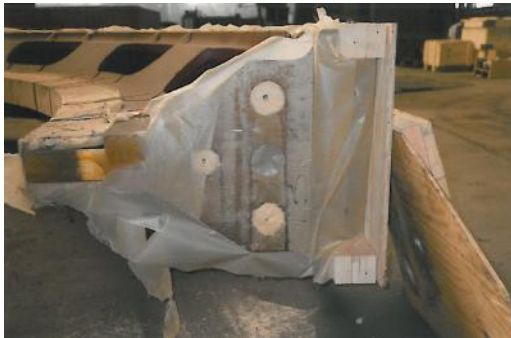

Image 30 shows protection of teeth with 8-10 mm plywood and retaining band.



Image 31 shows the sprocket wheel during securing in the load area on a ship.



**Bottom frame**

Must, as a minimum, have the same dimension as the goods or larger.

The clearance under all packaging must be a minimum 100 mm.

Support must be provided for unpacked equipment. This is done by using leg bolts on the flanges of equipment or by welding to the structure, cradles attached to the goods etc.

2.2.8 **Unpacked/bottom frame - container.**

The equipment must be bolted securely to the bottom.

**The bottom should be the same size as the goods or larger and it must be possible to handle the bottom from 2 sides using a truck.**

Image no. 32



The image shows supports for Idlers, which are bolted together to the bottom frame and secured with wires.

Image No. 33 below shows:

Equipment unpacked on a steel bottom.

In this case the frame is used as foundation for the equipment, but the same type of frame can be used as a transport frame for other equipment.

Image no. 33



The above image also shows:

Electrical components where mounted on a machine part are considered to be one electrical part and are packaged as per Flow Sheet point 2.1. This requires dense packing, i.e. placement in container or closed crate. The entire machine part must therefore be considered to be one electrical part and

packaged in accordance with this unless the electrical parts are dismantled and packed separately or sealed onto the machine part (see 2.3.2). This must be approved by an FLSmith inspector.  
Image no. 34



The image shows supports for Idlers, where the "support leg" is secured to the bottom frame following placement, and fastening to the container is begun with steel wire.

**2.2.9 Cable drum**

A cable drum is taken to mean a drum with coiled-up material, e.g. cables, wire, tapes etc.

For coil-up on drums, one unit must, as a minimum, have the capability to form 10 layers. Max. one unit per drum, i.e. one tape or a full-length cable.

**Illustrations and dimensions**

Illustration no. 14

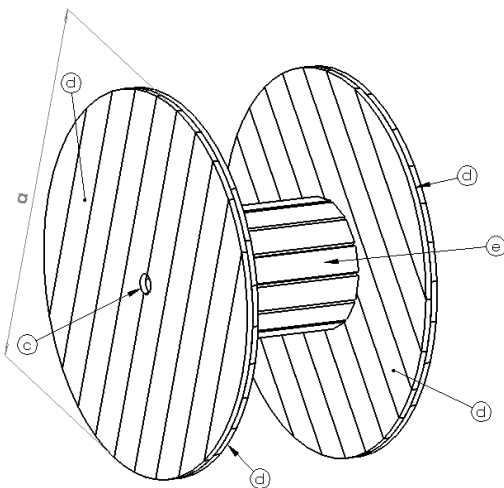

The sides are made up of two layers of boards placed at right angles to one another. In the innermost layer, the centre hole is adapted to the diameter (b) of the drum core.

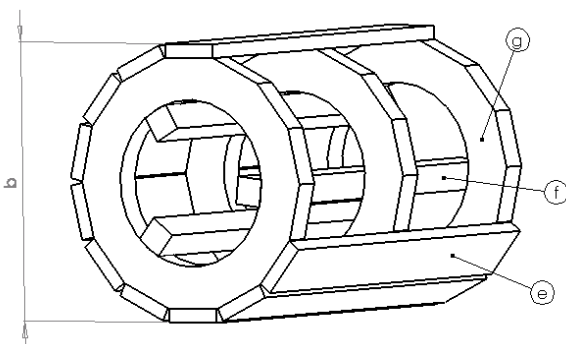

The plates (g) can be made as 2-4 composite parts.



a [mm]	B [mm]	c [mm]	d [mm]	e [mm]	f [mm]	g [mm]
700	400	80	25 x 100	25 x 100	50 x 50	25
1000	500	80	25 x 100	25 x 100	50 x 50	25
1500	700	80	25 x 150	25 x 100	50 x 50	25
2000	800	80	25 x 150	25 x 100	50 x 50	25

Image no. 35



The image shows three sizes of cable drums. The protective boards are nailed to the sides.

Image no. 36



The image shows:  
There is a steel reinforcement ring in the centrehole.

Drum is assembled by means of nuts and large flat discs on 6 through-going treaded rods.

## 2.2.10 Barrels on pallets

### General notes

Bulk material can be shipped in barrels. The most obvious examples are paint, oil and large quantities of bolts, nuts, small castings etc.

Image no. 37



### Definition of dangerous goods/classified goods see Point 1.9.7.

### Positioning and fixation

It is essential to ensure that the barrels are placed on the pallet so that they are made to rest on the entire bottom edge. The barrels must be fixed to the pallet using steel strips and must subsequently be packed in foil.

## 2.3 Lining, packing and protection

### 2.3.1 Lining of closed box and light box

Lining is taken to mean cladding of the inner sides of the box. The function of the box lining is to protect against ingress of water.

**The following material or similar can be used:**

**Plastic foil of polyethylene (LDPE) with a minimum thickness of 150 µm.**

### Method

When fitting lining in a box, one full-length plastic piece should be used, to maximum practicable extent, for every side and for the cover. The plastic pieces must have an allowance/overlap circumferentially of about 100 mm, which must be bent over the top edge to form an overlap at the corners of the box. The plastic piece for the cover must also have an allowance of about 100 mm at all edges which must be bent over the top edge of the sides. Plastic to be fixed using a staple machine.

If the dimensions of box necessitate use of more than one piece of plastic for each side, it is essential to ensure that the pieces overlap one another by minimum 50 mm. This overlap must also be ensured at the corners of the box; overlapping must be done so that water is prevented from entering the box at the joints.

See the diagram on the next page.

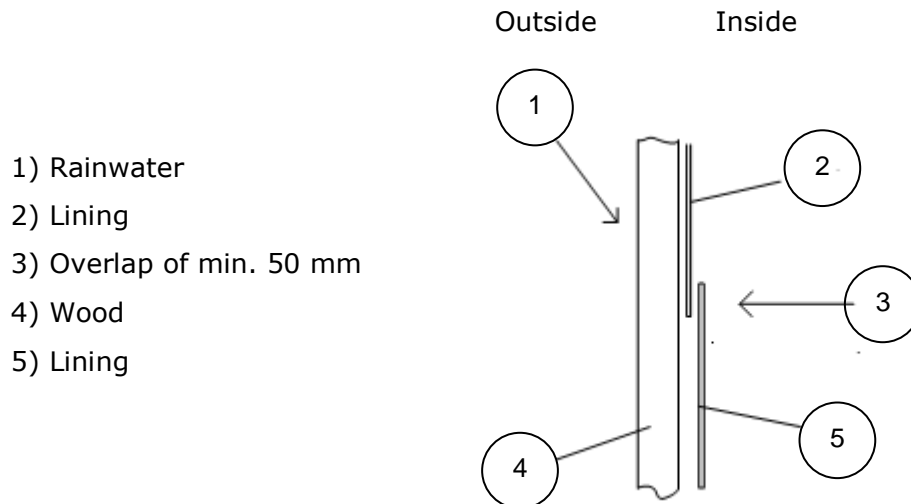

Plastic must be fitted internally to the cover of the box, using a water-proof plate to fix the plastic in order to prevent water accumulations between the cover and the plastic.

**A LINING MUST NEVER BE FITTED AT THE BOTTOM OF THE BOX.**

### 2.3.2 Dense packing

A dense packing is taken to mean a water-proof packing in aluminium foil. For this packing it is very important to protect the edges and corners of the equipment to prevent damage to aluminium foil. This packing is primarily used for electrical parts and to protect parts not deemed suitable for rust-proofing by means of tectyl.

The signage "Desiccated pack", re. Point 4.4., symbol L, is applied to the box to signify that the box contains goods that may not be opened before the goods are used on Site.

#### **Protective layer**

Various non-water absorbing materials can be used as protective layers.

For example: plates/corners of foam plastic, rubber mats, etc.

#### **Method**

If densely packed:

1. Protective layers must be fitted to the sharp edges and corners of the equipment in order to protect the aluminium foil from damage and perforation. Keep the equipment in original packing.
2. Place the equipment in the aluminium bag.
3. Fit sealing discs at the bolt holes if the equipment is bolted to the box.
4. Place desiccant bags around the equipment inside the bag (and inside the equipment if it is an air-tight unit). Consumption of desiccant, see appendix 4.3.
5. The desiccant bags must not be in direct contact with non-painted surfaces.
6. Weld the foil, except for approx. 50 mm.
7. Suck some of the air out of the bag. Vacuum must not be allowed to form in the bag.  
For loose items placed in foam chips all air must be sucked out of the bag.
8. Weld the final 50 mm of the foil.

### 2.3.3 Valved packing

Valved packing is taken to mean that the equipment is covered by means of a plastic cap, i.e. with the equipment covered on top and sides by one piece of plastic to prevent hard-driven water/rain from penetrating the equipment. Do not use plastic pieces made up of tape or similar means. If the plastic cap is to be made of several plastic pieces, these pieces must be assembled by welding.

Material, see section 2.3.5.

### 2.3.4 Protection

Protection is taken to mean protection applied directly to the goods.

Protection of the equipment may be divided into two categories. Protection against corrosion and protection from impacts and shocks. Protection against impacts/shocks may be dispensed with if the selected type of packaging provides the required level of protection in this respect.

For electrical equipment, protection must always be provided in the form of 50 mm foam plastic as shock-absorbing material.

Material, see section 2.3.5.

### 2.3.5 Materials for packaging and fillers

**Wood;** All wood used for the execution of packaging and appertaining stiffening elements in the must be of a quality corresponding to :  
**EN 12246-2000. Class P1**

**All must be treated in accordance with**

ISPM 15 (International Standards for Phytosanitary Measures)

**ONLY use whole lengths of boards/posts.**

**Nails:** Use cross threaded steel nails.

**Shock-absorbing and protective materials;**

For example, use plates or inserts made of polystyrene, rubber or similar between sections. The material **ETHAFOAM** is recommended, which is environmentally friendly and an active shock absorbing material.

**Fillers;**

If fillers and protective material are used, this must be an artificial product such

as polystyrene, plastics, rubber, styrene plastic, foam plastic.

**Water-absorbing materials such as wood shavings, straw, cardboard and paper must not be used.**

**ALUMINIUM FOIL;**

Aluminium foil is used in dense packaging and must be in PP 007 bags (see data sheet in section 4.2) or equivalent material.

**Desiccant;**

Bags containing the desiccant Bentonite must conform to DIN 55473 and the specifications in DIN units.

3 desiccant units per square metre of aluminium foil must be used for the packing.

For example, 10 m<sup>2</sup> foil:                      10 m<sup>2</sup> x 3 units = 30 units



### **Disposal of packaging and fillers;**

Packaging and fillers must be disposable in accordance with international standards, such as ISO 26000.

(ISO Social Responsibility standard - ISO 26000)

## **2.4 Electrical equipment**

### **2.4.1 General notes**

For packing of electrical equipment for FLSmidth, a distinction is made between the following categories of packaging:

#### **A - General cargo:**

Seaworthy packing of equipment to be shipped by truck, railway, aircraft and ship and undergoing several transshipments while in transit.

Such packaging must be stackable. Also the packaging must protect the equipment against varying climatic conditions during the period from the time of shipment to the time of arrival at site (normally 24 months), unless otherwise agreed.

#### **B - Container transport:**

Container packaging for equipment to be shipped in containers.

Such packaging must be stackable and able to withstand shocks and impacts occurring while in transit. Also the packaging must be capable of protecting the equipment while it is stored in the container subject to varying climatic conditions during the period from the time of shipment to the time of arrival at site (normally 24 months), unless otherwise agreed

The equipment is chosen on the basis of its strength characteristics during transit and storage.

The packaging directions indicate typical examples of equipment ordered by FLSmidth.

#### **2.4.1.1 Tagging/marking of LV/MV equipment etc. following sampling/FAT;**

Example 1; When copper busbars are used to secure multiple modules, the copper busbars must be marked with a separate tag that belongs to the units that have been used.

Example 2; When loose parts (cables, screws etc.) are packed, all parts must have a tag that identifies each individual part.

**IMPORTANT; ALL MARKINGS ON SEPARATE LV/MV AND OTHER ELECTRICAL UNITS MUST ALSO BE CLEARLY STATED ON THE OUTER SIDE OF THE PACKING/CRATE WITH NECESSARY FIELD NO.**

(example; 401MV100-Q04 or 301LV100-NA01).

**ALL DESIGNATIONS MUST ALSO BE CORRECTLY STATED IN THE PACKING LIST!**

Any deviation from that stated above in point 2.4.1.1. will result in the supplier/order recipient being held financially liable for any charges that are incurred by FLS in connection with the procurement of necessary information and any visits to Site by FLS technicians in order to identify and ensure correct assembly in order to fulfil FLS's contractual obligations to our customers, see general purchase conditions.

Container packing lists;

Suppliers of electrical equipment delivered in containers must ensure that the supplier or its collaborating partners prepare a stowage plan that clearly indicates the physical placement of each individual package in the container. The stowage plan must be sent as an appendix together with submission of the packing list to the WEB packing list system, <http://packinglist.flsmidth.com> .

The example below shows a Container packing list and an example of how a stowage plan/container summary should appear;

Container package list;

<b>FLS PACKING LIST</b>		Number		Sh. 557		
Customer:		"F.C.K.S. Fabrica de Cimento do Kwanza Sul LDA		FLS Contract No. 08-45180		
				FLS ref. 4-0845180-215685A / 10003		
Packages:	Weight kilos	Weight Kilos	Dimensions (L x W x H) mm			
1	Gross	Net	L	W	H	
SHOC 40' HC	16820	-----	12190	2440	2900	
			86,256 CBM			
<b>Container Number:</b>	UACU4972939					
<b>CSC Number:</b>	USA/AB-922/92-0					
<b>Valid Until:</b>	2013-3-30					
<b>Seal Number:</b>	AM73660					
<b>FLS MARK:</b>	<b>PACKING:</b>	<b>NO.</b>	<b>GR.WEIGHT KGS.</b>	<b>NET WEIGHT KGS.</b>		
4-0845180-215685A/41	Case	1	650	595		
4-0845180-215685A/42	Case	1	650	595		
4-0845180-215685A/43	Case	1	650	595		
4-0845180-215685A/44	Case	1	650	595		
4-0845180-215685A/45	Case	1	650	595		
4-0845180-215685A/46	Case	1	650	595		
4-0845180-215685A/47	Case	1	650	595		
4-0845180-215685A/48	Case	1	650	595		
4-0845180-215685A/49	Case	1	650	595		
4-0845180-215685A/50	Case	1	650	595		
4-0845180-215685A/51	Case	1	650	595		
4-0845180-215685A/52	Case	1	650	595		
4-0845180-215685A/53	Case	1	650	595		
4-0845180-215685A/54	Case	1	650	595		
4-0845180-215685A/55	Case	1	650	595		
4-0845180-215685A/56	Case	1	650	595		
4-0845180-215685A/57	Case	1	650	595		
4-0845180-215685A/58	Case	1	650	595		
4-0845180-215685A/59	Case	1	650	595		
4-0845180-215685A/60	Case	1	650	595		
<b>TOTAL:</b>	<b>PACKAGES</b>	20	13000	11900		
<b>Tara of Container:</b>			3820			
<b>Total Gross Weight of Container:</b>			16820			

<b>Container Plan of Sumbe (MV Switchgear)</b>	
<b>Contract: 08-45180, PO: 215670</b>	
<b>10001</b>	
<b>Container Number: TRIU9042458</b>	
<b>CSC Number: F/BV/4119/93</b>	
4-0845180-215685A/1 ; 801MV100+Q01	4-0845180-215685A/2 ; 801MV100+Q03
4-0845180-215685A/3 ; 801MV100+Q05	4-0845180-215685A/4 ; 801MV100+Q15
4-0845180-215685A/5 ; 201MV100+Q01	4-0845180-215685A/6 ; 201MV100+Q03
4-0845180-215685A/7 ; 301MV100+Q02	4-0845180-215685A/8 ; 301MV100+Q04
4-0845180-215685A/9 ; 401MV100+Q04	4-0845180-215685A/12 ; 401MV100+Q05
4-0845180-215685A/10 ; 401MV200+Q01	4-0845180-215685A/13 ; 401MV200+Q04
4-0845180-215685A/11 ; 501MV100+Q01	4-0845180-215685A/14 ; 501MV100+Q03
4-0845180-215685A/15 ; 501MV100+Q04	4-0845180-215685A/16 ; 502MV100+Q0 1
4-0845180-215685A/17 ; 501MV100+Q05	4-0845180-215685A/19 ; 501MV100+Q06
4-0845180-215685A/18 ; 501MV100+Q07	4-0845180-215685A/20 ; 501MV100+Q08
<b>Door opening</b>	

## 2.4.2 Packaging directions for export packaging A

**Table for packaging directions A. Unit goods and B. Container**

Equipment type	Examples of products	Outer packing	Inner cladding/ Notes	Special Symbol Statement	Statement of storage symbol (ref. 39401-01-4.0)
Electrical panels	All panels	Closed box	* ***	Symbol L, Point 4.4 (all panels) + Tilt Indicator fig. P + Shock Indicator fig. O	D
Motors > 1000 kW		Crates			C
Electrical equipment	Components with electrical equipment	Closed box	*		D
Instruments	Temperature transmitters Pressure transmitters etc.	Closed box	* **	Symbol L, Point 4.4	D
Motors with IP44 degrees of protection or greater		Crate			C
Engines with degree of protection less than IP44		Closed box	**		D
Distribution and power transformers for outdoor installation		Crate	***		C
Rectifiers for electrostatic precipitators for outdoor installation	Pulse tanks etc.	Crate	***		C
Station equipment for outdoor installation	Cable separators Switches Instrument transformers	Crate crate			C
Cable trays		Crate boxed /bundles			B/C
Master		Bound			A
Insulators for filters		Closed box	Protective layer, plate form along the box's sides and between the insulators		D

\* Ref. 2.3.2.

\*\* Ref. 2.3.1.

\*\*\* Ref. 2.3.4

Marking with symbol for storage and handling (see sections 2.4.2 & 4.4)  
Goods and Packaging must be marked with symbols defined as follows;

- A Outdoor storage. (Heavy unpacked goods)
- B Outdoors storage (Unpacked goods)
- C Covered storage (protection against direct sunlight and rain)
- D Closed constructions, heated and/or ventilated storage

A letter must be applied to the packaging, separately and in accordance with the instructions as stated in Point 1.10.2

#### 2.4.3 Means of transportation and dismantling of equipment

Transportation of large and/or bulky equipment necessitates dismantling of parts to allow for the limitations of the transport vehicle with regard to dimensions and weight. For example, radiators and expansion tanks on large transformers are dismantled. The top and base parts of central control panels are also dismantled.

Please consult our logistics unit in case of any questions concerning the limitations of the specific transport vehicles.

#### 2.4.4 Packing of electrical equipment and lining of boxes

##### **Electronic equipment which is very sensitive to shock impacts, moisture and temperature fluctuations**

For shipment between suppliers (see section on local transport):

Use both external and internal packaging of a non-hygroscopic, shock-absorbing material.

In connection with shipment for testing:

Place the equipment in the original packaging, closing it with tape and wrapping plastic aluminium foil around it. Place the packed equipment in a closed wooden box, made of tongued and grooved boards as specified in section 2.2.1.

##### **Dense packing**

Control and display panels with electronic components:

Place bags with desiccants in or at the equipment, and wrap plastic aluminium foil around the equipment. Use an impulse rod for weld-up of foil.

Compliance with the following points must be ensured:

1. Attach the desiccant bags inside the equipment/packing. Avoid any direct contact between bags and the electro technical components. Distribute the bags evenly within the area of packaging.
2. Execute continuous welded seams.
3. Packing must be done so that the foil is positioned as smoothly as possible.
4. Place sealing discs around the bolt holes if equipment is bolted to the box.
- 5. Important:** Place the support on the sharp corners and edges of the equipment to protect the foil against damage and perforation.

Small non-enclosed equipment with electronic components:

Place bags containing desiccant in each single packing. The desiccant must not get into contact with the electro technical components.

Equipment supplied in original packaging:

Keep the original packaging around the equipment and wrap it up separately in welded plastic aluminium foil. We recommend the use of **ETAFOAM boxes** as original boxes.

Equipment supplied unpacked:

First, wrap bubble foil around the equipment and subsequently use welded plastic aluminium foil.

Where appropriate, several parts can be packed together in a package of welded plastic aluminium foil after bubble foil has been wrapped around the individual parts.

### **Valved packing**

Cover the equipment with plastic foil which is closed at the sides, acting as a cap.

Place support at the sharp corners and edges of the equipment to protect the foil against damage and perforation.

### **Lining of closed boxes**

For closed boxes where the equipment is not packed in welded aluminium foil as valved packing, see section 2.4.4.

#### 2.4.5 Placing equipment in boxes

- Shaft ends on motors and other corroding surfaces must be rust-proofed prior to being packed.
- Protect exposed surfaces (e.g. lacquered surfaces or covers made of clear plastic) to avoid wear marks from the boards and bearers of the box. For example place adhesive tape on the contact faces of the equipment.
- Parts separately supplied must be carefully fixed. For example, fix foundation rails to the box by means of bolts.
- Secure motor bearings which may sustain damage in transit and during handling.
- Always insert plugs in screwed connections and cable lead-ins, and if possible place the equipment in the box so that any ingress of water is dispelled on the casing of equipment.

## **3 Stowing of container**

### **3.1 Container transport, general notes**

Goods stowed in containers must be packaged as securely as possible, ensuring that goods cannot move during transport.

It must be possible to move the goods using a forklift truck.

See section 2.2.3 and 2.4.2 for suitable types of packing for stowing of container.

### **3.2 Container types**

For container transport, the Shippers Own Containers (SOCs) are used, i.e. purchased containers since they are to be used for storage/as a store at site during a period of up to 1 year after arrival.

Consequently, the container must meet the following requirements:

- Visible CSC-plate with a validity of minimum 1 year
- No perforation due to rust or deformations
- Intact sealing strips at doors
- No dry rot in bottom boards
- The container must be wind- and water-proof

Containers must be delivered in accordance with ISO 668, i.e. standard 20' dc,  
40' dc,  
40' hc,  
20' fr  
or 40' fr are acceptable.

The internal dimensions for the most common containers are indicated in the table below:

**PLEASE NOTE** that the dimensions may vary slightly from container to container

Internal dim. 1	Length [mm]		Breadth [mm]		Height [mm]		Max Total weight [kg]*
External dimension 2	1	2	1	2	1	2	
20' container	5860	6060	2330	2440	2380	2590	20.000
Door opening			2286		2261		
40' container	11998	12190	2330	2440	2380	2590	27.000
Door opening			2286		2261		
40' container high cube	11998	12190	2330	2440	2655	2900	28.000

\*payload must always be physically checked on the door of container.

### 3.3 Stowing

It is very important that the goods are stowed and shored up in the container, which means that the equipment must be fixed everywhere in the container by means of nails, screws, bolts, welding and lashing.

Any displacement, however small, of a unit will unleash significant forces which may have a destructive impact on packaging and equipment, and may, in worst-case scenario, cause the container to break loose in transit.

When wood is used to make braces or arresting mechanisms, such wood must be treated according to ISPM 15 (International Standards for Phytosanitary Measures).

### 3.4 Marking

The container must be marked with the lowest order number for parts stowed in the container, and from package number 10001 and upwards:

Example 1: 4-0645057-119110/**10001**

Example 2: 05-930145-01/**10001**

#### 3.4.1 Placing of units

Optimum stowing of the container is achieved by:

- ensuring that the point of gravity is kept as low as possible
- ensuring even load distribution on the bottom of container
- packing plate parts in vertical position – where feasible
- fixing the equipment to the bottom of the container
- fixing the equipment with fixed connections (bolts, welding, stop blocks)



Image no. 38



Image no. 39





## 4 Data sheet

### 4.1 "Pre-shipment" Inspection

#### 4.1.1 Procedures for pre-shipment inspections

1. The pre-shipment inspection will consist of the following:
  - a. Visual general inspection of the goods (not technical)
  - b. Inspection of quantities as per packing lists submitted by FLSmidth
  - c. Inspection of quality of the packing
  - d. Inspection of quality of the packing materials
  - e. Inspection of tagging of goods to be shipped
  - f. Inspection of marking of packaging to be shipped
  
2. The following documents will be provided for the pre-shipment inspection
  - a. RFI (Request for Information)
  - b. Advice of readiness
  - c. Packing List
  - d. E-mail with request for inspection incl. information whether the goods will be seaworthy packed or packed for subsequent containerisation.

The Pre-shipment inspection must be carried out, by the buyer or his appointed inspection company.

**4.2 Aluminium foil**

## Technical Data Sheet

### Protective Packaging

#### No. TDS03B

### PP007

12 micron	Polyester Film
15 gsm	LDPE Bonding Layer
7 micron	Aluminium Foil
30 gsm	LDPE Bonding Layer
70 gsm	Black ribbed HDPE
Overall thickness 165 -175 microns +/- 5% tolerance	

#### **TECHNICAL VALUES / PERFORMANCE**

Nominal Substance	(gsm)	avg. 151.5 (146 -157)
Tensile MD	(kgI50mm)	19.6-20.2
Tensile CD	(kgI50mm)	21.5-24.7
Puncture Resistance	(N)	85-95
Tear MD	(N)	29-33
Tear CD	(N)	25-29.5
MVTR (Tropical)	(g/m <sup>2</sup> /24Hr)	<0.05
Stiffness MD	(N/m)	58-63
Stiffness CD	(N/m)	75-84

Notes: MD = Machine Direction  
 CD = Cross Direction

Tropical MVTR Conditions = 38°C, 90% Relative Humidity  
 Sealing Conditions 180°C, 10psi, 2 Second dwell time

**CLASSIFICATION:** DEF STAN 81/75 TYPE 1

This material is made from materials approved for food contact under the appropriate F & D Regulations.

The information is given in good faith but must not be regarded as forming a specification.

### 4.3 Desiccant



Tyvek 1/3 unit      Tyvek 4 units      Non-Woven 8 units      Non-Woven 16 units      Mini-pax 2g

<b>Tyvek</b>	<b>4 g</b>	<b>8 g</b>	<b>12.5 g</b>	<b>25 g</b>	<b>50 g</b>	<b>100 g</b>	<b>200 g</b>	<b>250 g</b>	<b>400 g</b>	<b>500 g</b>	<b>1,000 g</b>
Unit	1/6	1/3	1/2	1	2	4	8	10	16	20	32
Dimension (mm)	33 x 65	35 x 90	60 x 100	60 x 120	60 x 140	60 x 170	130 x 180	130 x 190	13 x 270	210 x 270	210 x 300
Number per box	2500	1000	1000	400	250	100	50	50	25	25	1
<b>Non-Woven</b>	<b>6 g</b>	<b>12 g</b>	<b>18 g</b>	<b>35 g</b>	<b>70 g</b>	<b>130 g</b>	<b>260 g</b>	<b>540 g</b>	<b>1,120 g</b>		
Unit	1/6	1/3	1/2	1	2	4	8	16	32		
Dimension (mm)	33 x 63	33 x 89	65 x 80	63 x 115	62 x 135	80 x 147	120 x 193	110 x 250	187 x 295		
Number per box	2500	1000	1000	400	250	100	50	50	25		
<b>Mini pax</b>	<b>1 g</b>	<b>2 g</b>	<b>3 g</b>								
Dimension (mm)	19 x 36	22 x 44	25 x 44								
Number per box	1000	600	400								

Desiccants in Tyvek and Non-Woven qualities are available from 1/16 to 32 units. The unit is an **international standard** and indicates the moisture capacity - 1 unit having the capacity to absorb 5gm of moisture.

Three factors will determine the amount of desiccant to be used:

1. Tightness of packing (does air escape, allowing moisture to enter from the outside?)
2. The amount of excess air in the packaging surrounding the product (a full packaging contains smaller amount of air/moisture than a half-full packaging).
3. The composition of the product (does the product itself contain, and hence emit, moisture?)

Contact the supplier to determine what is most suitable for the specific packaging assignment.

**4.4 Survey of symbols for handling and storage;**

- Electrical packaging must carry the LETTER stated in the table, point 2.4.2 in order to inform how the goods must be stored upon arrival at the Customer. (ref. instruction 39401-01-4.0) The letter must be entered in the same size as the shipment marking.



**A special marking symbol is also used on the outside of boxes that contain foil packaged goods. (SYMBOL: L)**

**General marking designations:**

A	This side up	F	Centre of gravity	L	Do not destroy barrier Sealed packing
B	FRAGILE – <b>Handle with care</b>	G	Sling / Strap here	M	Temperature limitations
C	Keep Dry <b>To be stored under cover</b>	H	Do not use hand truck	N	Do not use forklift truck here
D	Keep away from heat	J	Clamp here	O	Shock Indicator <b>Handle with care</b>
E	Use no hooks	K	Stacking limitation To be transported and stored on top.	P	Tilt Indicator <b>Handle with care</b>

A		F		L	
B		G		M	
C		H		N	
D		J		O	
E		K		P	

Further information can be find in the standards EN ISO 780 and DIN 55 402