

ODS Diaphragm Pump



What it is

The ODS is an air-operated diaphragm pump. Because it is a diaphragm pump, it is superior to centrifugal and helical screw pumps for heavy-duty performance. Because it is an air-operated diaphragm pump, it is significantly superior to mechanically or hydraulically operated models due to its simplicity of control and evenly distributed power transmission.

The ODS pump, is superior to other air-operated diaphragm models because it is designed and built for truly long-term, year-in-year out, heavy-duty performance. It weighs more – two or three times more than air-operated double diaphragm pumps – lasts longer, and pumps the slurries that no other unit can handle. There is no truly equivalent unit.

What can it pump

It will efficiently transfer anything that moves through a pipe such as:

- Delicate crystal slurries.
- Highly concentrated and unusually viscous slurries.
- Highly abrasive slurries.
- Highly corrosive slurries.
- Very large solids in slurries.
- Extremely volatile slurries.
- Delicate and unstable slurries.
- Air entrained slurries.
- Shear sensitive liquids.

Additional advantages.

- The ODS Pump can be automated to match capacity to process requirements for maximum process efficiency.
- The ODS Pump's construction allows it to be operated dry, indefinitely. It cannot air bind, has no stator to burn out, no seal to fail.
- The ODS Pump has no seal, so contamination of process slurry or the environment from seal leaks is not possible.
- The ODS Pump is adjustable while in operation for maximum flexibility for both capacity and discharge pressure.
- The ODS pump is a low maintenance pump –once installed it requires almost no attention.
- The ODS can handle tough corrosives, abrasives, temperatures up to 200°F, and slurries containing up to 75% solids. The rhythmic plunger-type action minimizes particle degradation of even the most delicate materials. Operation is completely leak-proof.

*Spring Assist ODS Pump Model 4E
with Quick Opening Ball Check Valves.*

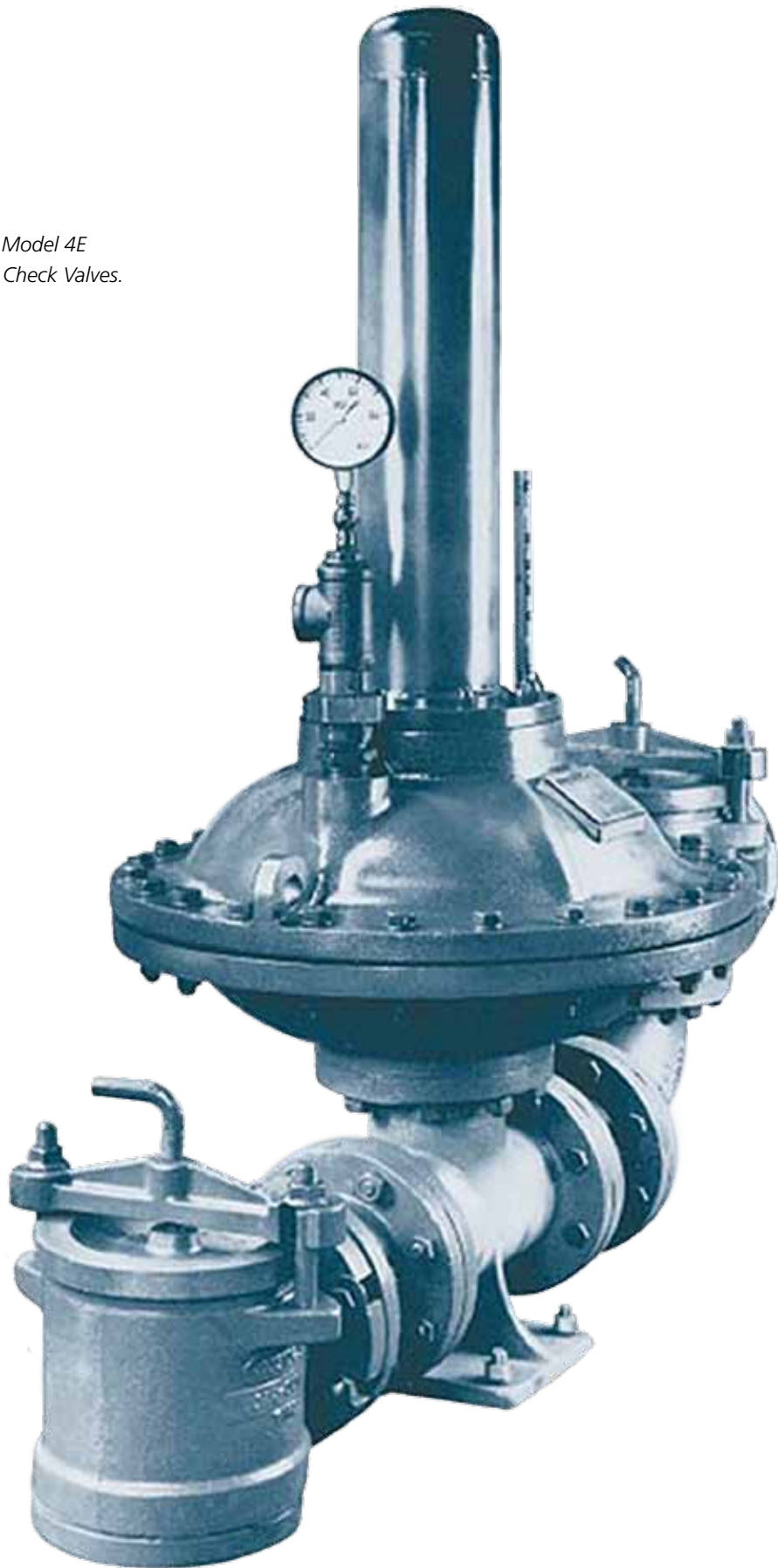

How the ODS pump works

The non-assist ODS pump

Fill stroke.

To fill the pump cavity, positive suction head (inlet pressure) is required. When inlet valve A is lifted by the pressure of the suction head, the slurry completely fills the pump cavity. The diaphragm returns to its normal convex position and the air exhausts. Discharge valve B, seated by line pressure, prevents slurry from returning to the pump cavity.

The minimum positive suction head required is 2 PSI above that at the level of the pump diaphragm centerline.

If suction lift is required, use Spring-assist or Air Cylinder-assist model.

Discharge stroke.

Compressed air is admitted to the chamber above the diaphragm. The diaphragm descends gradually increasing the pressure in the pump cavity. This, in turn, closes inlet valve A and causes discharge valve B to open when the line pressure is exceeded. Further movement of the diaphragm displaces the slurry from the pump cavity. The pumping action is positive yet gentle so that delicate crystals and slurries can be transferred or metered without damage.

Electrical impulses from an adjustable timer alternately open and close the solenoid controlled air valves which admit and exhaust air from the diaphragm cavity.

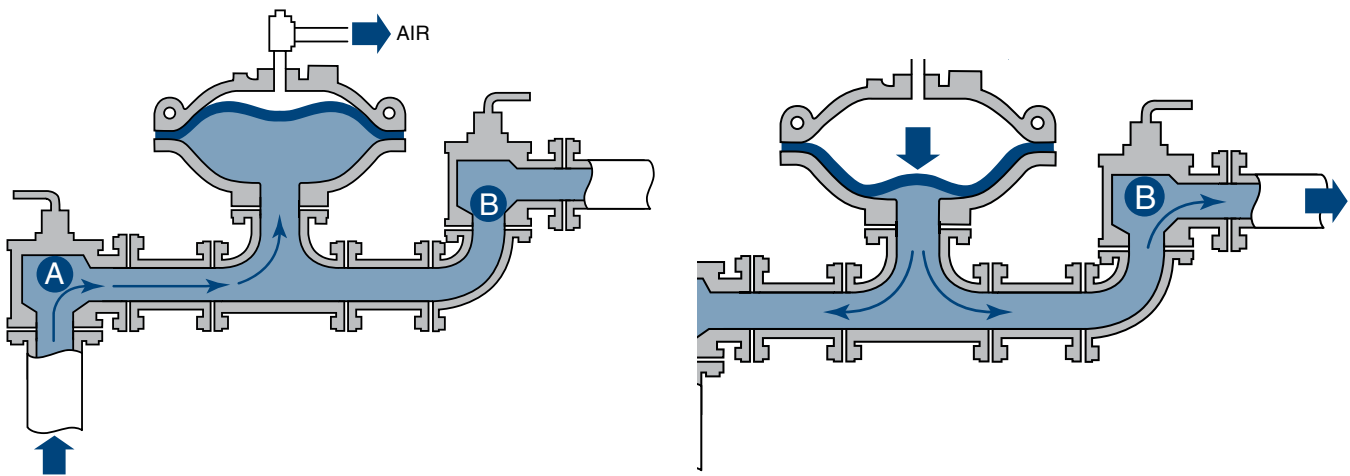

Spring Assist ODS Pump

In this model, a version of the basic pump, the diaphragm is mechanically lifted by a spring actuated rod. The spring is cocked during the discharge cycle by the air pressure driving the diaphragm downwards. The discharge cycle is the same as in the basic pump. This self-priming model is recommended for applications where:

- Suction lift is up to 10 feet.
- Normal capacity is increased up to 50% due to faster filling action.
- Slurries with high solids concentration and high viscosity can be handled.

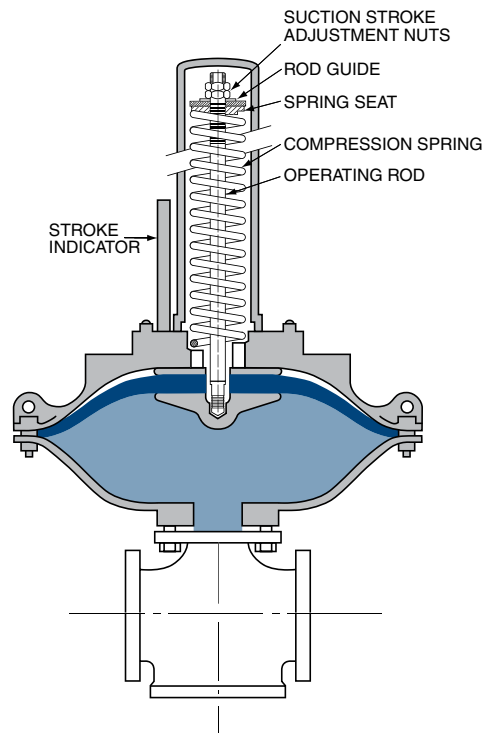

Air Cylinder Assist ODS Pump

In this version of the basic pump, the diaphragm is mechanically lifted by an air cylinder actuated rod. At the top of the lift stroke, the air is directed into the diaphragm chamber driving the slurry out of the pump cavity and simultaneously returning the air piston to the lower position.

This model is used for applications requiring:

- Suction lift up to 20 ft.

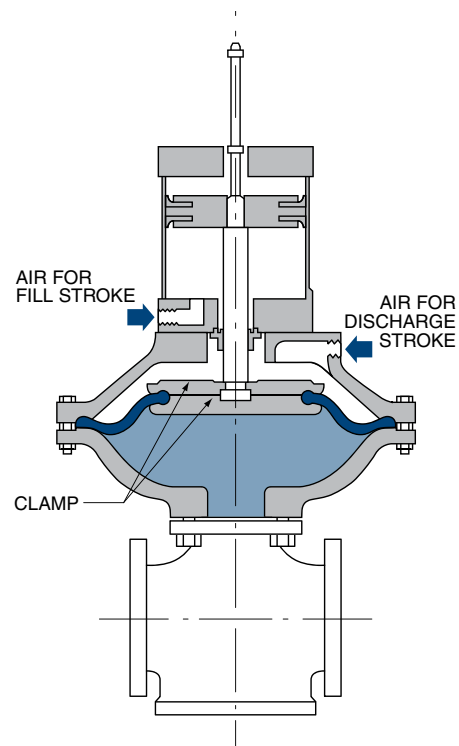

ODS pump components and controls



Variable timer.

Controls the operation of the solenoid valve to set the number of pumping cycles per minute and the length of the discharge portion of each cycle. The timer can be automated for paced control in response to a 4-20ma signal. The timer is housed in a protective fiberglass enclosure with a hinged cover, NEMA Type 4. Multiple pump operation options are available.

Remote or linear response timers are also available. The variable timer is available in several designs.

Timers are solid state electronic or PLC with a wide variety of timing ranges and options, such as stroke counters and terminals for remote

operation. An automatic pressure control system to feed a plate and frame filter press is available to control single or multiple feed pumps.

Pump cover

Cast iron.

It incorporates the port for the air connection and lifting lugs to facilitate installation. It has a sturdy flange at the rim where it bolts to the casing. The cover also is reinforced with radial ribs and code designed (ASME pressure vessel code) to withstand 100 PSI operating pressure.

Diaphragm

Molded of tough flexible Nordel® (EPDM), neoprene, food grade, or Viton® optional to withstand various requirements. Reinforcing nylon fabric is strategically located within the diaphragm to provide maximum life under repeated flexure. The uniformity and precision-construction of the multilayered Dorr-Oliver diaphragm is the key to its long service.

Pump casing

Cast iron - standard.

Cast iron lined with Nordel (EPDM) or neoprene is optional. 316 S/S is optional. Radially located grooves assure complete slurry discharge from the pump cavity. No solids can remain to abrade the diaphragm.

Base tee

Cast iron - standard.

Cast iron lined with Nordel (EPDM) or neoprene is optional. 316 S/S is optional. The base tee connects the check valves and the pump casing. It also serves as an equipment support base for the pump assembly.

Control Valve

Solenoid operated, threeway valve. It admits and releases compressed air to move the diaphragm. This valve is normally closed.

Check Valves

Available in three models and different materials of construction to meet process requirements. (See page 9)

Air Chamber

Used in applications where there is a high head on the suction and/or discharge side of a pump requiring high air pressure. The air chamber acts as a cushion, eliminating water hammer, noise and pulsations.

Regulator

Controls air pressure to desired operating conditions.

Muffler

Reduces the noise of outrushing air so that the pump operates very quietly. Less than 85 DBA at 5' on the "A" scale.

Typical ODS Pump Assembly

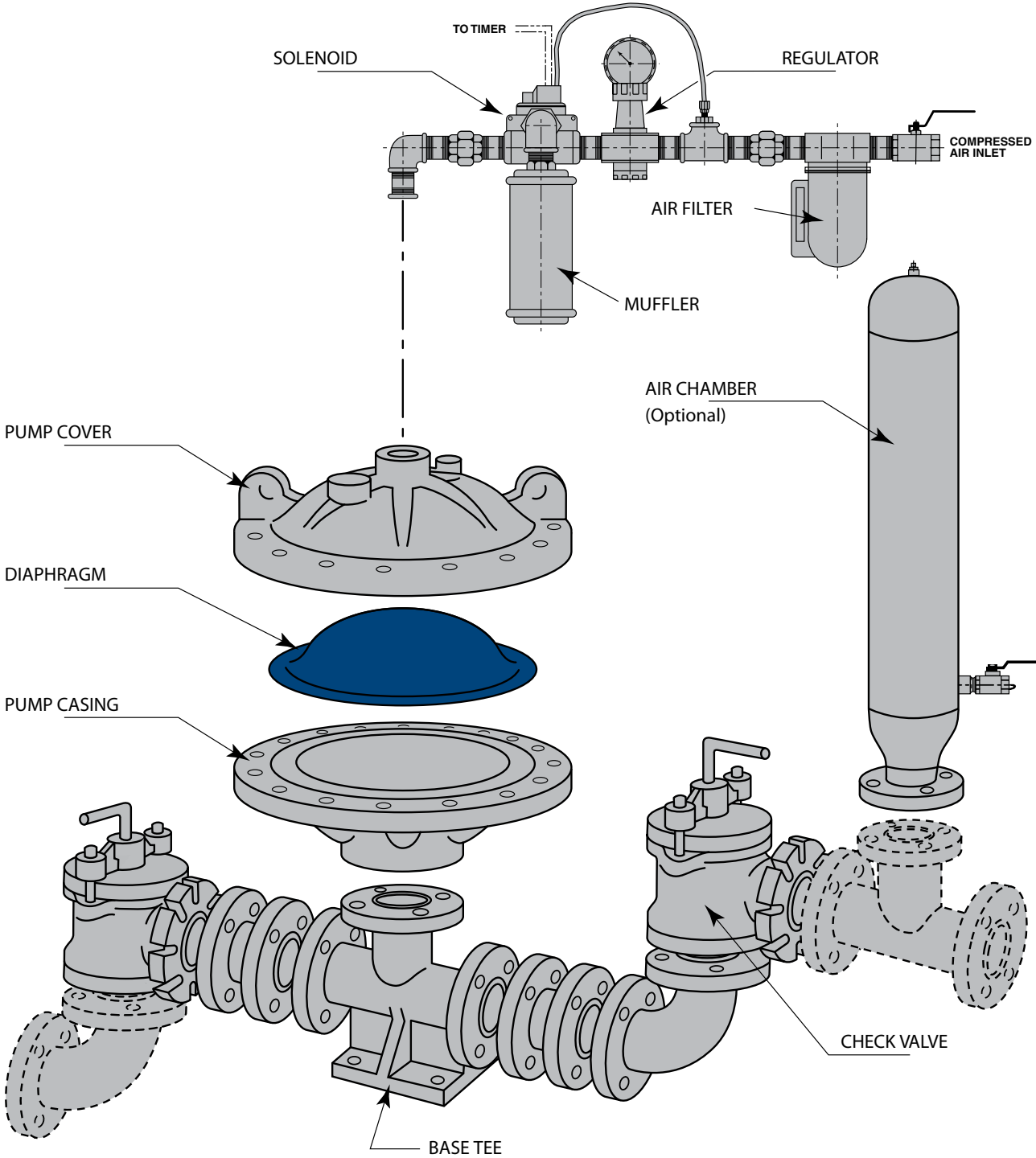

How the ODS pump works

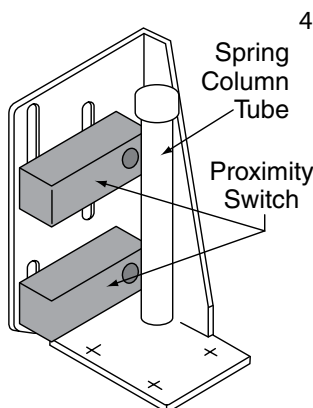
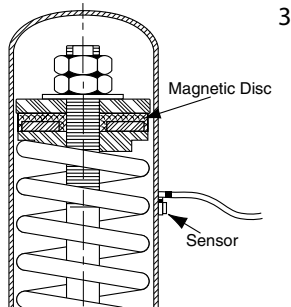
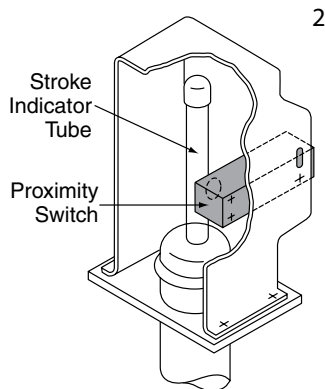
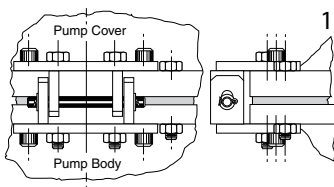

Hinge Assembly (Fig. 1)

The hinge assembly increases the ease of maintenance when replacing or inspecting diaphragms. The assembly is also available as a retrofit kit for existing pumps.

Discharge Stroke Position Sensor

A. Spring Assist Pumps

(Model # 2S & 2BS) Fig. 2

(Model # 3E & 4E) Fig. 3

Current design provides a sensor located on the spring column tube which is activated by a magnetic disc in the spring assembly. Existing equipment can be refitted by mounting a proximity sensor to the spring column tube. The sensor is activated by entering the magnetic field.

B. Air Cylinder Assist

Pumps (Fig. 4)

For air cylinder pumps the proximity sensor and bracket is mounted on top of the air cylinder.

Constant Flow & Automatic Pressure Adjustment

(F&PA)

This feature automatically adjusts the air pressure to meet varying operating conditions. The system is available for new as well as retrofit pumps.

Controllers

- Single pump controller (std.)
- Multi-range w/ contacts for remote start/stop.
- 4-20 MA Controller
- Synchronization for 2 units in parallel.
- Multi-pump controller

Diaphragm Failure Moisture Detector

To alert the operator of sudden diaphragm failure, a Moisture Detector Probe can be installed above the diaphragm.

Automatic Pressure Control System

Designed specifically for feeding a plate and frame filter press. System continuously increases the feed pressure from minimum to maximum while the flowrate is continuously reduced from maximum to minimum.



Choose any of Three Check Valves

Type Q: Quick-opening ball-check valve

This is the valve supplied unless another is specified. It is an all-around performer. A quick opening yoke permits easy cleanout and inspection without breaking piping. Positive seating of the ball is assured by gravity and guiding ribs. Ball and seat is replaceable.

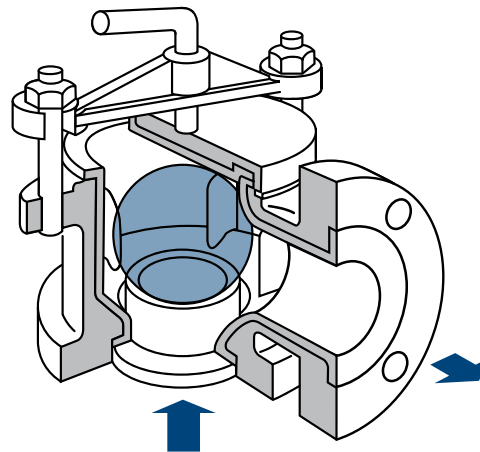

Type B: In-line ballcheck valve

The valve is highly efficient hydraulically with flow passing vertically straight through. It is used in applications where maintenance is infrequent. Streamlined internal design reduces the potential for material to clog or hang up. Positive seating of the ball is assured by gravity and line pressure.

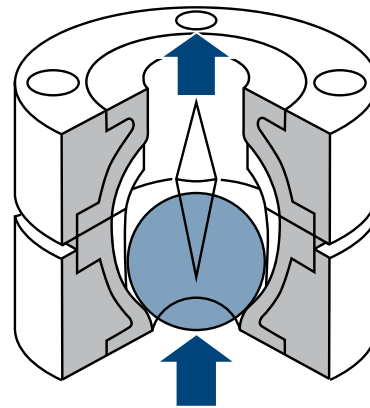

Type F: Flap-check valve

This valve is recommended when it is necessary to pass large, pipe-size solids without clogging. Removable cover and flap permit inspection and cleaning without breaking piping. A special elastomer disc is installed on the flap to ensure sealing, reduce noise and increase life of the valve. Flow is straight through.

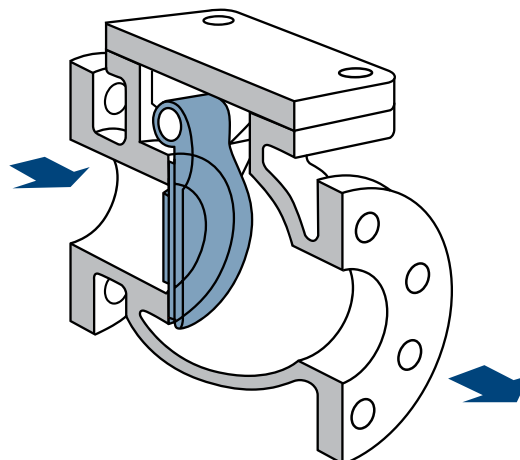

How to size and specify the right pump for your particular job

	Basic Pump	Spring Assist	Air Cylinder Assist
Flooded suction Low viscosity	✓		
Medium viscosity		✓	✓
High viscosity			✓
Suction lift Up to 10 ft (water)		✓	✓
10 ft up to 20 ft (water)			✓
Discharge head above 185 ft	✓		✓
Electric Controls	✓	✓	✓
Pump Parts	Available Materials of Construction		
Diaphragm	Nordel (EPDM) (optional) Neoprene (optional) Viton A (optional)		
Casing Base tee Q-valve	Cast iron unlined Cast iron lined with Hypalon (opt.) Cast iron lined with Nordel (optional) Cast iron lined with Neoprene (optional) 316 S/S unlined (optional)		
Cover	Cast iron		
Flap valve	Cast iron 316 S/S (optional)		
In-line valve	Cast iron lined with Nordel (EPDM)		

Selection

Step 1: Pump Model Selection.

Consider pumping requirement, slurry viscosity and specific gravity, and suction conditions. Note that higher specific gravity slurries require greater suction lift capability than water. See chart on the upper left.

Step 2: Material Selection.

Material of construction is selected based on slurry characteristics – corrosive, abrasive, temperature. See chart on the lower left.

Step 3: Air Requirement.

Determine the air requirement based on pumping capacity and discharge need. See performance data on page 12/13.

Step 4: Control Selection.

Specify manual or automated control system.

Limitations.

Maximum working pressure.....100 psig

Maximum hydrostatic pressure...150 psig

Maximum operating temp....200°F (94°C) with elastomer lining.

To properly size and specify the correct ODS Pump for a given application, there is certain basic information required:

- Is positive suction head available?
- What is the maximum discharge head?
- What is the peak and normal capacity?

- What is the maximum suction lift?
- What is the slurry characteristic? (Specific gravity of liquid and solids and Viscosity).
- What is the slurry temperature?

The answers to these questions will dictate how your pump is to be built.

Chemicals and Solutions	Nordel	Viton	Chemicals and Solutions	Nordel	Viton
Acetic acid	A	C	Isoclone	-	A
Acetic acid, glacial	B	C	Isopropyl alcohol	-	A
Acetic anhydride	A	C	isopropyl ether	C	C
Acetone	A	C	JP-5 Fuel	C	A
Aluminum chloride	A	A	Kerosene	C	A
Aluminum sulfate	A	A	Lacquer solvents	C	C
Ammonia, anhydrous	-	C	Lactic acid	A	A
Ammonium hydroxide	A	A	Linseed oil	B	A
Amyl acetate	A	C	Magnesium chloride	A	A
ASTM oil No. 1	C	A	Megnesium hydroxide	A	A
Asphalt		A	Methyl alcohol	A	B
Barium hydroxide	A	A	Methyl ethyl ketone	A	C
Beer	A	A	Methylene chloride	B	B
Benzene	C	B	Mineral Oil	C	A
Boric Acid	A	A	Naphtha	C	A
Bromine, anhydrous liquid	C	A	Naphthalene	C	A
Butane	B	A	Nitric acid, 30%	B	A
Calcium chloride	A	A	Nitric acid, red fuming	C	B
Calcium hydroxide	A	A	Nitrobenzene	A	B
Calcium hypochlorite, 5 - 20%	A	B	Oleic acid	B	B
Carbon bisulfide	C	A	Perchloroethylene	C	A
Carbon tetrachloride	C	A	Phenol	B	A
Chlorobenzene	-	A	Phosphoric acid, 20 - 70%	A	A
Chloroform	C	A	Pickling acid	C	A
Chromic acid, 10 - 50%	A	A	Potassium dichromate	A	A
Citric acid	A	A	Potassium hydroxide	A	A
Copper chloride	A	A	Sea water	A	A
Copper sulfate	A	A	Sodium hydroxide	A	C
Cottonseed oil	A	A	Sodium hypochlorite	A	B
Creosote oil	C	A	Sodium peroxide	A	A
Cyclohexane	C	A	Soybean oil	C	A
Ethyl alcohol	A	A	Styrene	C	A
Ethyl chloride	B	A	Sulfur, molten	A	A
Ethylene glycol	A	A	Sulfur, trioxide	B	A
Ethylene oxide	-	-	Sulfuric acid, 5 - 10%	A	A
Ferric chloride	A	A	Sulfuric acid, 90%	C	A
Formaldehyde, 40%	A	A	Sulfuric acid, fuming (20% oleum)	C	A
Formic acid	A	C	Sulfurous acid	C	A
Gasoline	C	A	Toluene	C	B
Glue	A	A	Trichloroethylene	C	A
Glycerin	A	A	Tricresyl phosphate	A	A
n-Hexane	C	A	Tricresyl phosphate	A	A
Hydrochloric acid, 20%	-	A	Tung oil	C	A
Hydrofluoric acid, 75%	C	B	Turpentine	C	A
Hydrogen peroxide, 90%	-	A	Xylene	C	A
Hydrogen sulfide	C	B	Zinc chloride	A	A

Performance Data

Spring Assist ODS Pump

The capacity of the ODS pump depends upon its size, style and stroke rate. The performance data tabulated is for water with flooded suction and Quick Opening Ball Check Valves.

1. Water temperature at 60°F
2. Maximum performance at 100 PSI regulator setting
3. For lined pump max. performance is 10% less

Model 1^{1/2} S, 2S, 2BS
Spring Assist, 0 Ft Suction Lift

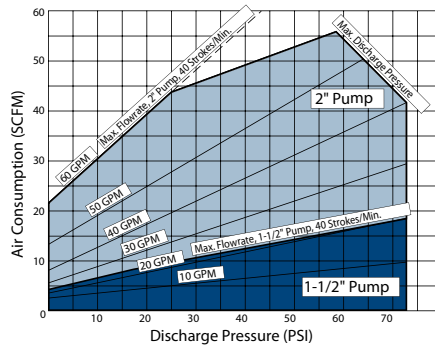

Model 1^{1/2} S, 2S, 2BS
Spring Assist, 10 Ft Suction Lift

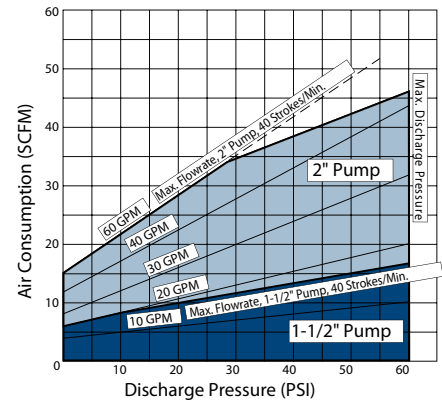

Model 3E & 4E
Spring Assist, 0 Ft Suction Lift

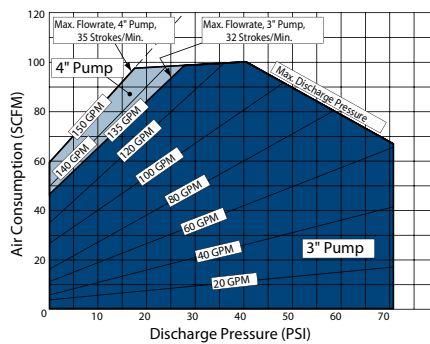

Model 3E & 4E
Spring Assist, 10 Ft Suction Lift

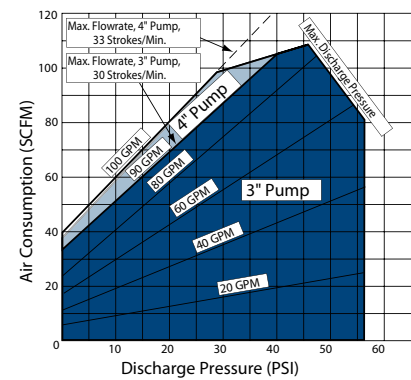

Performance Data

Air Cylinder Assist ODS Pump

The capacity of the ODS pump depends upon its size, style and stroke rate. The performance data tabulated is for water with flooded suction and Quick Opening Ball Check Valves.

1. Water temperature at 60°F
2. Maximum performance at 100 PSI regulator setting
3. For lined pump max. performance is 10% less

Model 3C & 4C
Cylinder Assist, 10 Ft Suction Lift

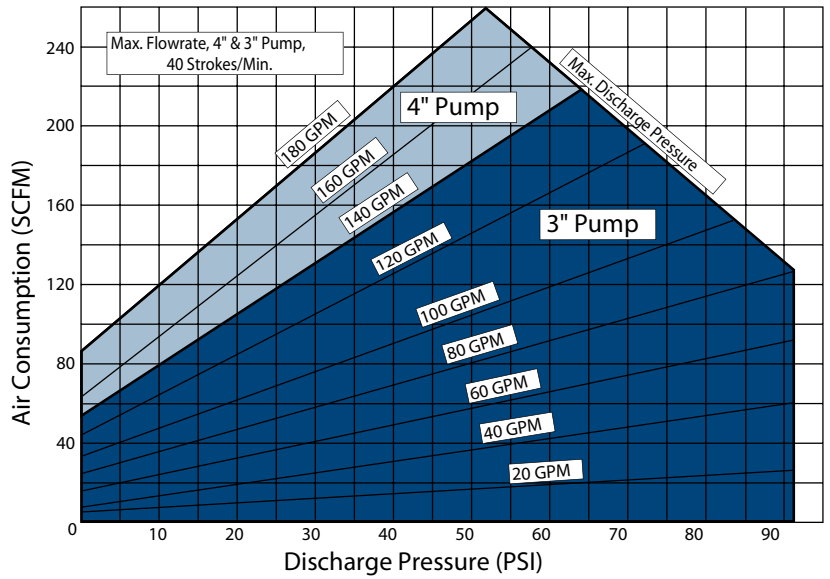

Model 3C & 4C
Cylinder Assist, 0 Ft Suction Lift

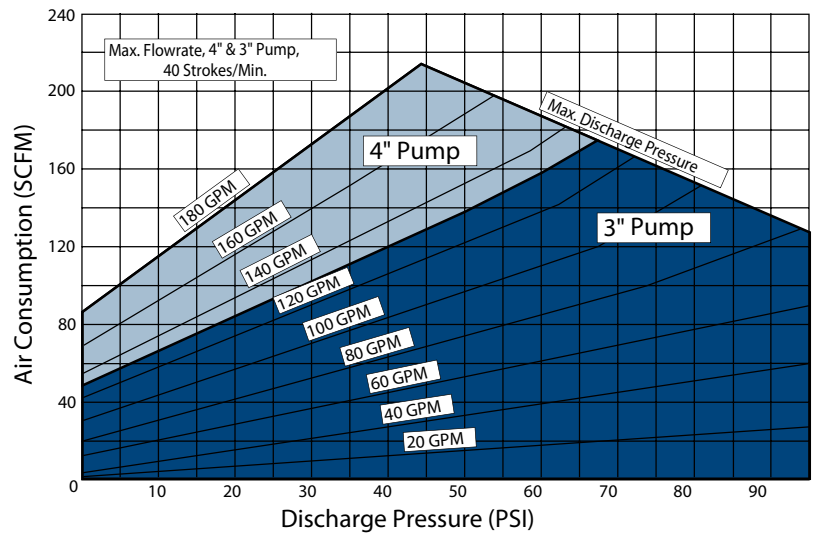

Dimensional Data

This data tabulation is for the three types of check valve arrangements and the three styles of ODS Pumps so as to assure the proper installation of the complete pump.

Type Q
Quick-Opening
Valve
Arrangement

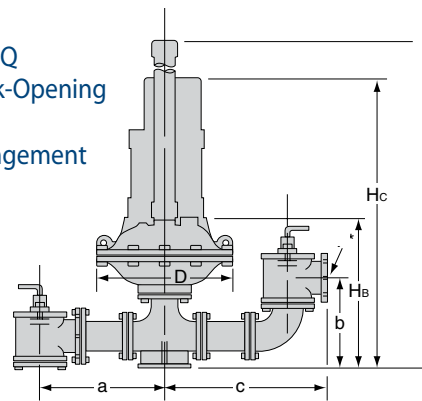

Type B
In-Line Valve
Arrangement

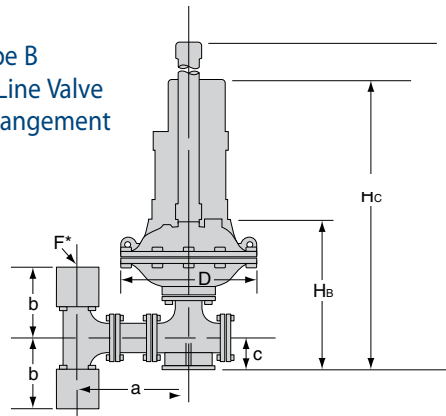

Type F
Flap-Check
Valve
Arrangement

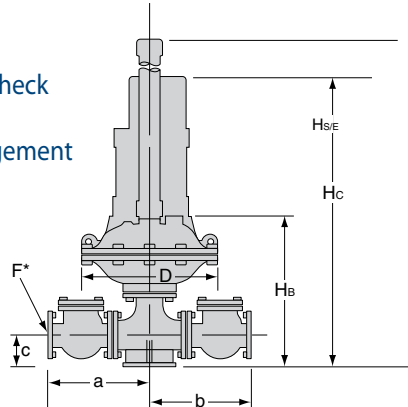

*Flanges are 125# ASA FF. Holes straddle centerline
SUB B = Basic pump

C = Cylinder assist
S = Size 1 1/2, 2, 2B Spring assist
E = Size 3, 4 Spring assist

Pump Size		1 1/2	2	2B	3	4
Hb	in mm	20 508	175/8 440	171 1/16 449	211 3/16 554	237/16 595
Hs/E	in mm	45 5/8 1159	69 7/8 1775	69 7/8 1775	49 1/2 1257	21 1/8 1299
Hc	in mm		39 990		45 15/16 1167	47 9/16 1208
D	in mm	12 305	16 1/2 419	16 1/2 419	24 1/2 622	24 1/2 622
F	inlet (outlet)	2	2	3 (2)	3	4
a	in mm	9 229	12 7/8 327	13 3/4 349	18 1/4 460	19 483
b	in mm	11 3/8 289	11 3/8 289	11 3/8 289	13 5/8 346	15 3/4 400
c	in mm	13 1/2 343	16 7/8 429	16 7/8 429	23 3/4 603	25 9/16 649

Pump Size		1 1/2	2	2B	3	4
Hb	in mm	15 3/16 386	17 15/16 456	17 15/16 456	21 13/16 554	23 11/16 602
Hs/E	in mm	39 3/4 1010	69 7/8 1775	69 7/8 1775	49 1/2 1257	51 1/8 1299
Hc	in mm					
D	in mm	12 305	16 1/2 419	16 1/2 419	24 1/2 622	24 1/2 622
F	inlet (outlet)	1 1/2	2	3 (2)	3	4
a	in mm	11 3/8 289	12 3/8 327	12 3/8 327	18 1/4 464	19 1/8 486
b	in mm	7 5/8 194	10 254	12 (10) 356 (254)	11 1/2 292	14 3/4 375
c	in mm	3 3/4 95	4 1/8 105	4 1/8 105	4 7/8 124	5 1/2 140

Pump Size		1 1/2	2	2B	3	4
Hb	in mm	14 356	17 5/16 440	17 11/16 449	22 559	23 5/8 600
Hs/E	in mm	39 3/4 1010	69 7/8 1775	69 7/8 1775	49 1/2 1257	51 1/8 1299
Hc	in mm				46 1168	47 5/8 1210
D	in mm	12 305	16 1/2 419	16 1/2 419	24 1/2 622	24 1/2 622
F	inlet (outlet)	1 1/2	2	3 (2)	3	4
a	in mm	12 305	12 1/2 318	17 1/2 444	14 3/4 375	18 1/8 460
b	in mm	12 305	12 1/2 318	12 1/2 318	14 3/4 375	18 1/8 460
c	in mm	3 3/4 95	4 1/8 105	4 1/8 105	4 7/8 124	5 1/2 140

How to install your ODS Pump

Location

Locate pump to have as short as possible suction line. Allow ample space for inspection and maintenance.

Air Header

Air pressure in pump should be set at 15 psi above the discharge head. Install air strainer/filter close to solenoid to protect air valve from loose pipe scale and other impurities. Install air pressure regulator and filter/strainer in accessible location. Use air chamber(s) to dampen surges due to high inlet or outlet pressures to prevent water hammer.

Noise

Muffler on air exhaust will keep operation quiet.

Foundation

Use anchor bolts into concrete column. Size stand to provide full support for base tee and to absorb vibration.

Solenoid Valve

Solenoid valves must be mounted upright. When handling toxic or corrosive material, recommend moisture detector to protect air header components and personnel.

Flanges

All flanges are 125# ASA FF.

Alignment

Pump should be horizontal and firmly mounted. Piping should be properly aligned and separately supported to prevent strain being transmitted into check valves and pump.

Piping

Size suction piping equal to, or larger than, inlet slurry valve. Avoid loops in piping and sudden changes in diameter. With two or more pumps discharging into same header, arrange piping so that entry is by means of a Y.



Pulse Transfer Thickening

www.flsmidth.com

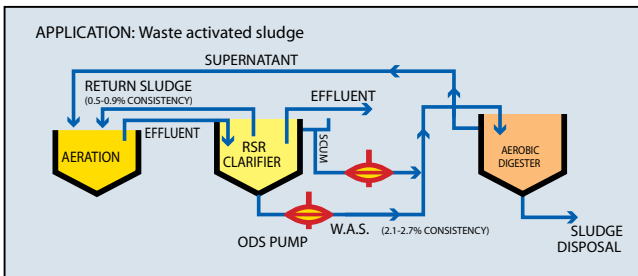
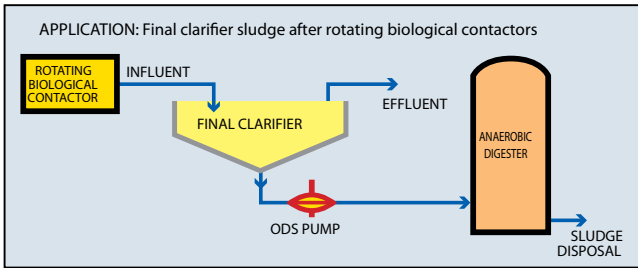
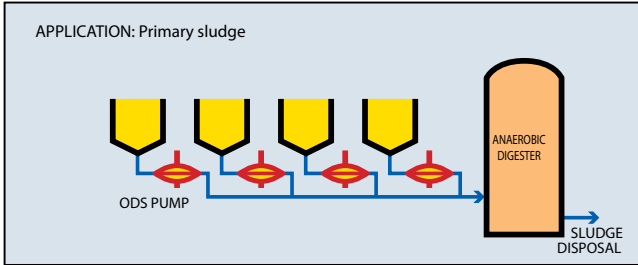

Another slight advantage of the ODS pump

FLSmidth's remarkable ODS pump does things to improve sludge handling that no other pump can do. We call it "Constant peak velocity pulse transfer thickening".

It is a concept in pumping that ends dilution of most sludges. In other words, no matter how much the pumping rate is reduced, ODS pumps continue to deliver constant peak scouring velocity. They work on most sludges including municipal sewage, primary clarifier underflow, aerated biological wastes, digested sludges and the like.

ODS pumps provide constant pumping velocity at all pumping rates. Pumping rates are matched to sludge accumulation rates. The result is an uninterrupted chain of operating benefits, improving all unit operations.

Minerals Processing Technology Center
 FLSmidth Salt Lake City, Inc.
 7158 S. FLSmidth Drive
 Midvale, UT 84047-5559
 USA
 Tel: 801 871 7000
 Fax: 801 871 7001
 Email: info.slcc@flsmidth.com