

KREBS gravelMAX™ Pumps



- Less down time
- Lower power consumption
- Patented externally adjustable suction-side wear ring



KREBS® gravelMAX™ Pumps

Markets & Applications

- **Aggregates (Sand Plants, Cyclone Feed, Tailings)**
- **Dredging**
- **Coal**
- **Froth (where air disbursement is a priority)**
- **Heavy-duty abrasive slurries**
- **Any application requiring the passage of large particles (hard hats not recommended!)**



Dredging Benefits

The gravelMAX™ Pump has a unique patented design developed for severe abrasive slurries. The gravelMAX™ Pump features a patented on-line wear clearance adjustment, which minimizes the cost-per-ton pumped compared to conventional hard metal and rubber lined slurry pumps through:

- Pump higher percent solids
- Increase deposit life by digging deeper
- Reduce power costs
- Reduce the cost per ton
- Adjust pump while running
- Longer wear life of parts



millMAX™ Solves This Kind of Problem

Competitor's suction liner and impeller at 550 hours



millMAX™ suction liner and impeller after 1500 hours of wear



PERFORMANCE.
PRODUCTIVITY.
PROFITABILITY.



millMAX™ PUMPS

Krebs millMAX™ Pumps treat the cause of pump wear and loss of efficiency, whereas competitive pumps treat the symptoms through materials or predictive uneven wear rates.

In most established millMAX™ installations, wear life of parts has been even and in the majority, overall wear life has generally improved by 50% to 100%. This increase in wear life is achieved together with a reduction in power, generally in the 10% to 20% or greater range.

The reduction in power can then be taken as a cost savings, or through additional pumping capacity with the same installed motor.

With the millMAX™ Hybrid Suction Sealing System, the front clearance is adjusted while the pump is running, and takes only five minutes to perform. This clearance is adjusted normally six to eight times throughout the life of the wet end parts.



10 x 8 Coal



12 x 10 Dredge Sand Slurry



8x6 Riversands

WET END CONVERSIONS

The millMAX™ design can be applied to an existing pump through a wet end conversion kit, including impeller, casing, backliner, and gland seal.

The millMAX™ conversion kit is supplied with an adapter ring, seals, and all hardware to adapt to a variety of power frames. This achieves the same results as a complete pump — on a maintenance budget.



20x18-46 Australia Gold



20x18-43 Australia Gold



6 x 4 Clay Pond



20x18-46 Quick-Release

gravelMAX™ Technical

WATER FLUSH SEAL Gland Water Required

SPECIFICATIONS

Slurry pumps are Krebs gravelMAX™ design and include the following:

CASING - designed for minimum slurry turbulence and even wear. Includes integral wear ring, carrier, and adjustment screws for on-line adjustment and elimination of suction side recirculation.

WEAR RING - adjustable wear ring assembly to permit closing of suction side impeller clearance during operation. This reduces slurry recirculation and lowers pressure at the suction area, thereby maintaining flow and reducing wear.

IMPELLER - designed for high slurry efficiency and hydraulic performance. Machined surface at the eye for wear ring adjustment and high expelling vanes.

BACKLINER - designed for close clearance at the back. Matching full impeller diameter and profile for close operating clearance.

WEAR PARTS - designed hydraulically to wear evenly. Constructed of high chrome at 680/720 Brinell hardness.

POWER FRAME - heavy duty cast iron pedestal with external bearing assembly adjustment mechanism. Drilled for overhead motor mounting assembly.

BEARING ASSEMBLY - heavy duty shaft and indirect fitted taper roller bearings rated at 100,000 hrs B-10 life minimum. Bearing arrangement designed to prevent over greasing and ingress of slurry.

FRAME	GPM
CMC	8
MMA	14
MMB	19
MMC	24
MMD	30

millMAX™ Power Frame

- Heavy duty cast pedestal.
- External bearing assembly adjustment.
- Wide bearing centers.
- Heavy duty shaft and bearings.
- Double clamp.

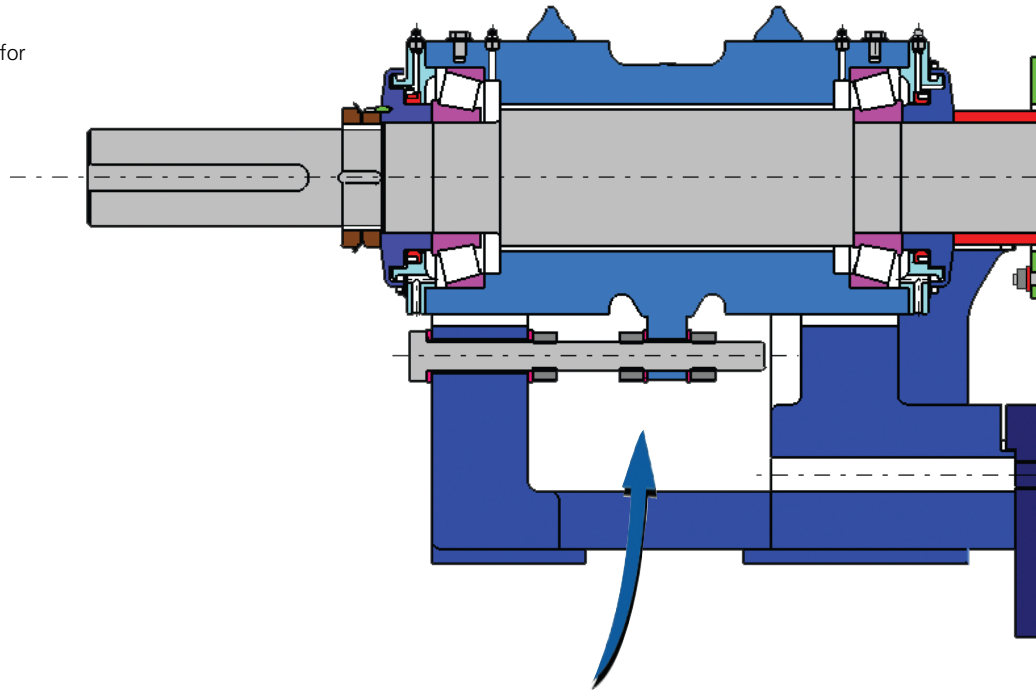
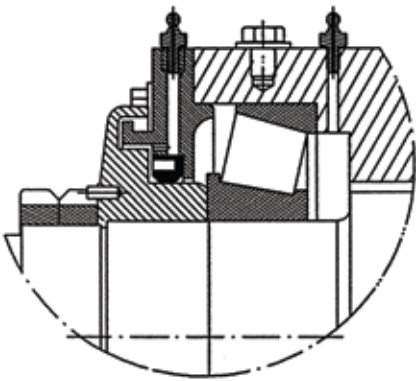

No adjustment of impeller once the pump is installed.

Reverse Taper Roller Bearings

- Increases effective load span to improve life.
- Main bearing failure is due to over greasing.
- Pumping action of taper rollers discharges grease to the outside, preventing ingress of slurry or over greasing of bearing cartridge.

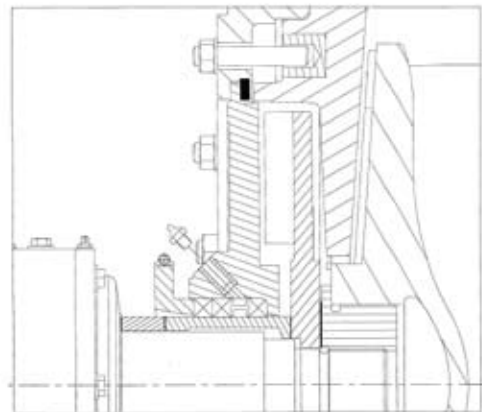

High Performance Centrifugal Dry Gland Seal

- Large expeller diameter generates high suction level sealing capacity.
- Zero leakage while operating.

CENTRIFUGAL SEAL

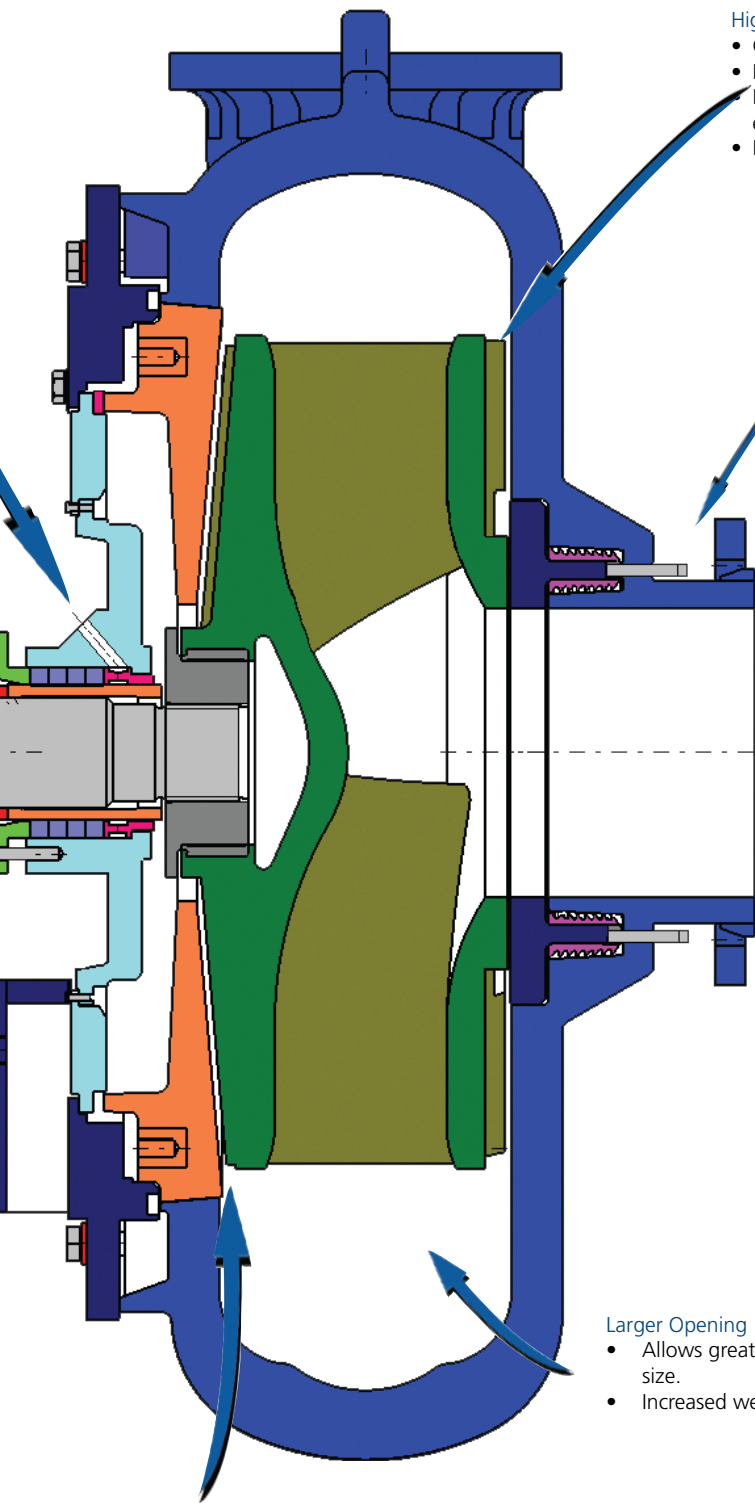

High Radial Vanes

- Clears large solids.
- Prevents solids from being crushed.
- Reduces casing slurry pressure at the eye of the impeller.
- Reduced power consumption.

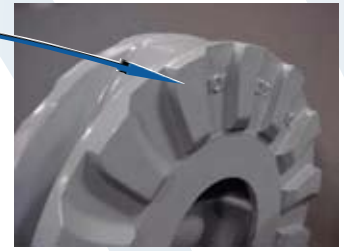

External Wear Adjustment Screw

- Four screws for on-line wear clearance adjustment.
- Adjusted while the pump is operating.
- Adjusted six to eight times during the life of the pump.



Adjustable Wear Ring

- Allows a higher percentage of solids pumped & maintained throughout the life of pump.
- Adjusted during operation.
- Reduces suction side recirculation.
- Maintains hydraulic performance.

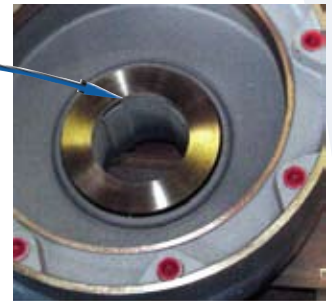

Larger Opening

- Allows greater maximum particle size.
- Increased wear life.

Narrow Clearance

Reduces pressure at gland to assist centrifugal dry gland seal or reduce gland water pressure.

driMAX™ Mechanical Seal

- Operates in extreme abrasive environment.
- Individual seal wear parts are easily replaced on-site without special tools.
- Ability to adjust for wear if required.
- Impeller suction wear clearance adjustment without touching seal.

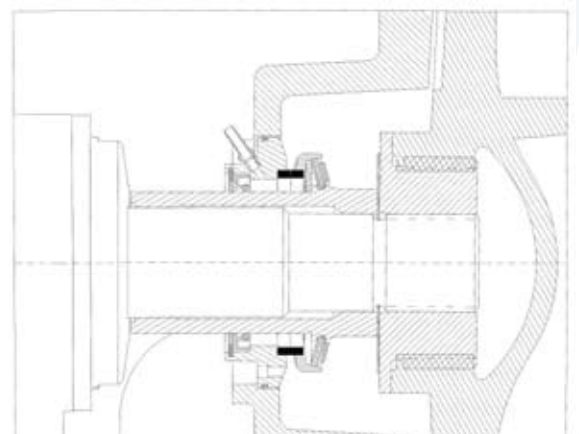

gravelMAX™ ENGINEERING DIMENSIONS

Standard gravelMAX™ Discharge Positions

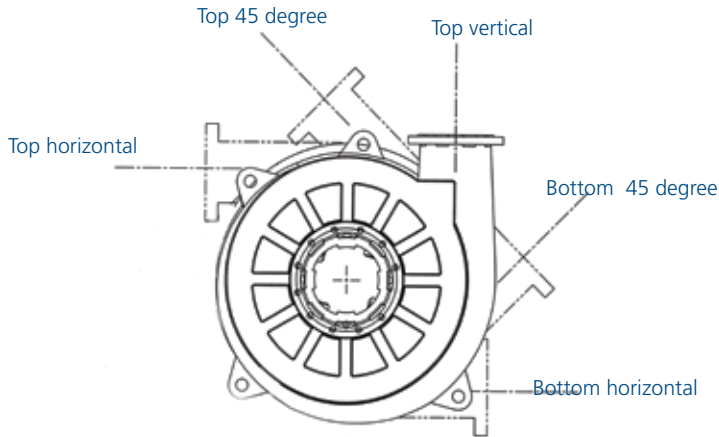

*NOTE: CONSULT FACTORY FOR OTHER DISCHARGE POSITIONS.

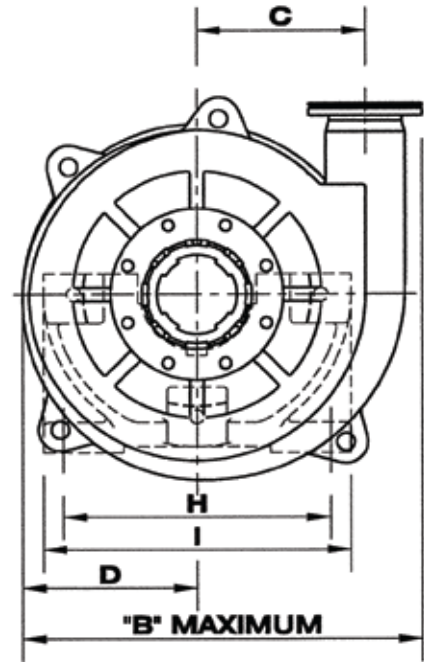

Pump Model	Size	Frame	A	B	C	D	E	F	F1	G	G1
GM150	6X4-16	MMB	1223 [48.1]	694 [27.3]	260 [10.2]	319 [12.6]	347 [13.7]	300 [11.8]	31 [1.2]	235 [9.3]	208 [8.2]
GM200	8X6-24	MMC	1601 [63]	1067 [42]	400 [15.7]	482 [19]	551 [21.7]	400 [15.7]	97 [3.8]	357 [14.1]	371 [14.6]
GM250	10X8-27	MMC	1578 [62.1]	1162 [45.7]	420 [16.5]	570 [22.4]	600 [23.6]	400 [15.7]	178 [7]	330 [13]	370 [14.6]
GM300	12X10-34	MMC	1759 [69.3]	1467 [57.8]	575 [22.6]	689 [27.1]	725 [28.5]	400 [15.7]	333 [13.1]	403 [15.9]	396 [15.6]
GM300	12X10-34	MMD	2035 [80.1]	1467 [57.8]	575 [22.6]	689 [27.1]	725 [28.5]	500 [19.7]	234 [9.2]	403 [15.9]	405 [15.9]

For reference only. Not to be used for construction.

Heart of the Design

The patented on-line suction side wear clearance adjustment permits the initial clearances to be maintained throughout the life of the pump. This extends the life of the impeller and suction wear faces to near, or equal that of, the casing for a one time maintenance rebuild.

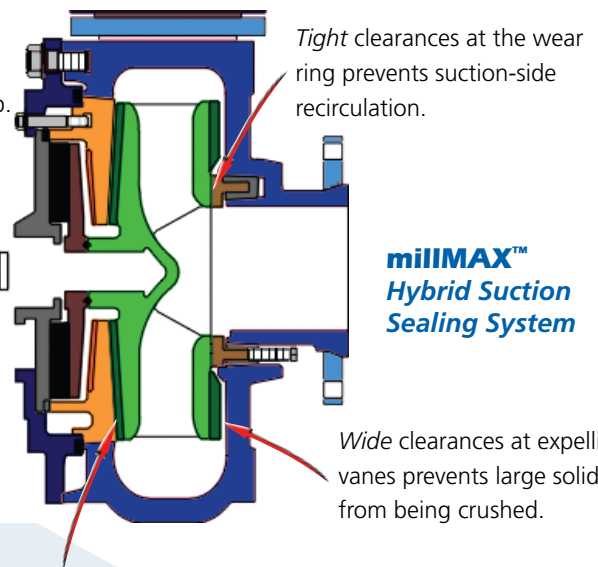
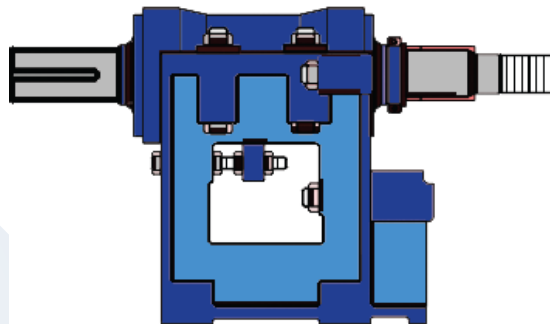

millMAX™
Hybrid Suction
Sealing System

The reduction of solids grinding between the impeller and suction side reduces power consumption and wear. The millMAX™ Hybrid Suction Sealing System maintains constant flow and pressure, without increasing speed or the danger of motor overload.

Tight clearances at backliner ensures that shaft sealing system works well.

- BARE SHAFT PUMP

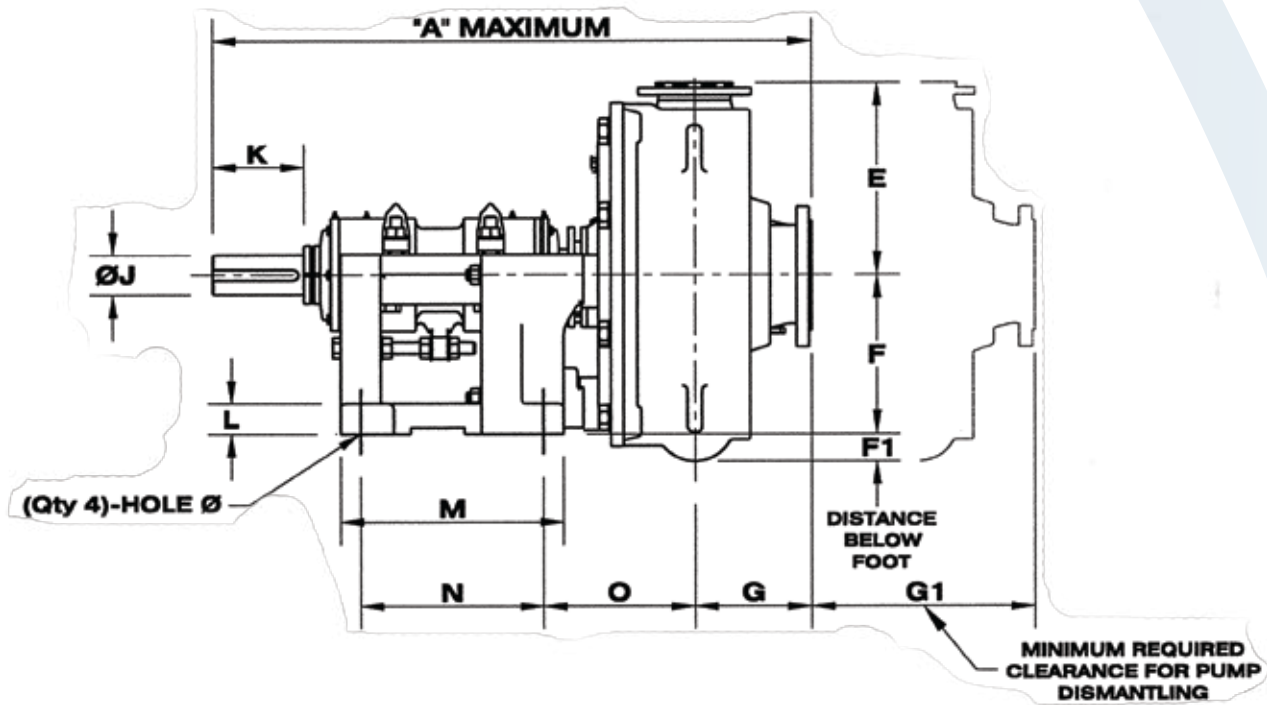

H	I	J	K	Key	L	M	N	O	Hole Dia.	Weight	Pump Model
475 [18.7]	548 [21.6]	80 [3.1]	215 [8.5]	14X22X150	50 [2]	410 [16.1]	335 [13.2]	315 [12.4]	29 [1.1]	725 [1599]	GM150
666 [26.2]	766 [30.2]	100 [3.9]	227 [8.9]	16X28X180	75 [3]	555 [21.9]	455 [17.9]	413 [16.3]	35 [1.4]	1560 [3440]	GM200
666 [26.2]	766 [30.2]	100 [3.9]	227 [8.9]	16X28X180	75 [3]	555 [21.9]	455 [17.9]	426 [16.8]	35 [1.4]	2698 [5949]	GM250
666 [26.2]	766 [30.2]	100 [3.9]	264 [10.4]	16X28X180	75 [3]	555 [21.9]	455 [17.9]	501 [19.7]	35 [1.4]	3719 [8200]	GM300
863 [34]	963 [37.9]	150 [5.9]	349 [13.7]	20X36X280	78 [3.1]	693 [27.3]	593 [23.3]	523 [20.6]	41 [1.6]	4439 [9788]	GM300

Copyright KREBS gravelMAX™ September, 2006

gravelMAX™ Pumps and gMAX® Sand Stacking Cyclones





Metal Slurry Pumps

The primary applications for the Krebs Metal Slurry Pumps are mill discharge, crusher slurry, sand and aggregate or any coarse solids or other severe, abrasive slurries especially in the copper, gold, iron ore, lead-zinc, coal, or phosphate plants. The most dramatic savings will be in these applications, though savings will also be realized on fine solids, like fine sand recovery or kaolin.



The key advantage of the Krebs Metal Slurry Pumps is the 10% to 30% lower power, long even wear life and less pump downtime, which results in lower cost-per-ton pumped, along with better cyclone separation.



- Adjustable Wear Ring - Allows for on-line adjustment of wear ring to minimize slurry recirculation.
- Hybrid Sealing System [patented] - Offers a wide clearance between the impeller and suction wear faces, plus unique Expeller Vane Profile, eliminates
- power consuming solids crushing and combined with the Adjustable Wear Ring, reduces slurry recirculation and wear to a minimum.
- Strategic Metal Distribution - Extra metal at the cutwater and other high wear areas combined with superior wear materials, result in even wear life.
- Ease of Installation - Customized designed spool pieces to suit existing pipe work.
- Cartridge Replacement - With even extended wear life, the case, impeller and backliner can all be replaced at the same time, reducing down time and maintenance costs.
- Fully Floating Shaft Seal - Ensures concentricity of gland packing and shaft sleeve during assembly for extended packing and sleeve life.
- Adaptor Plate - Wet end adapts to a variety of existing power frames.
- Optional Water Flush or Dry Gland Seal - Ability to eliminate gland seal water.

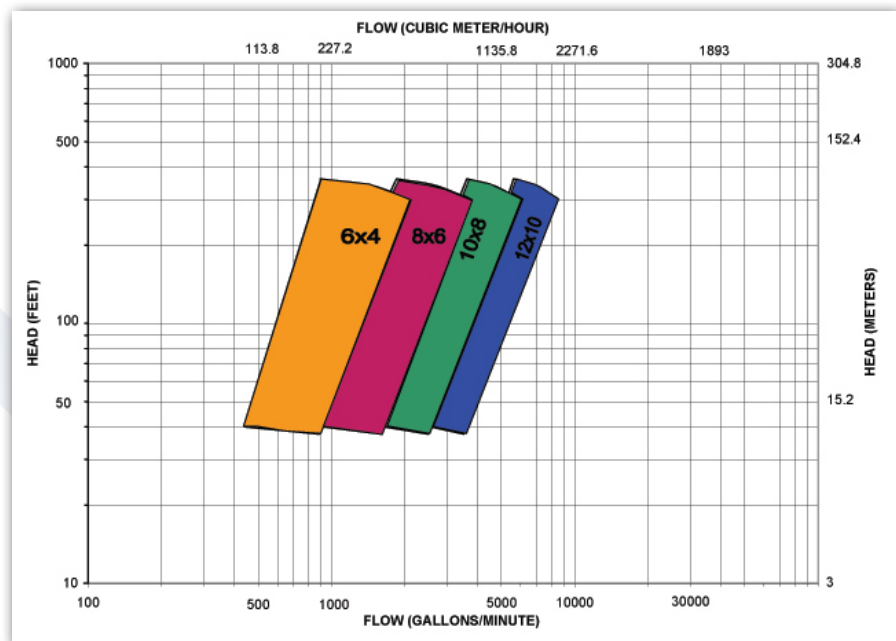

FLSMIDTH
KREBS

www.Krebs.com or
www.FLSmidthMinerals.com

©FLSmidth Group 2008. All rights reserved. This brochure makes no offers, representations or warranties (express or implied), and information and data contained in this brochure are for general reference only and may change at any time. Please contact FLSmidth Mineral for specific information or data that may relate to your interests