

Folaphone – Ball Mill Control by Electrical Ear

The FLSmidth Automation Folaphone system is designed for monitoring and supervision of the material charge in a ball mill. The system is developed for applications in the cement industry.

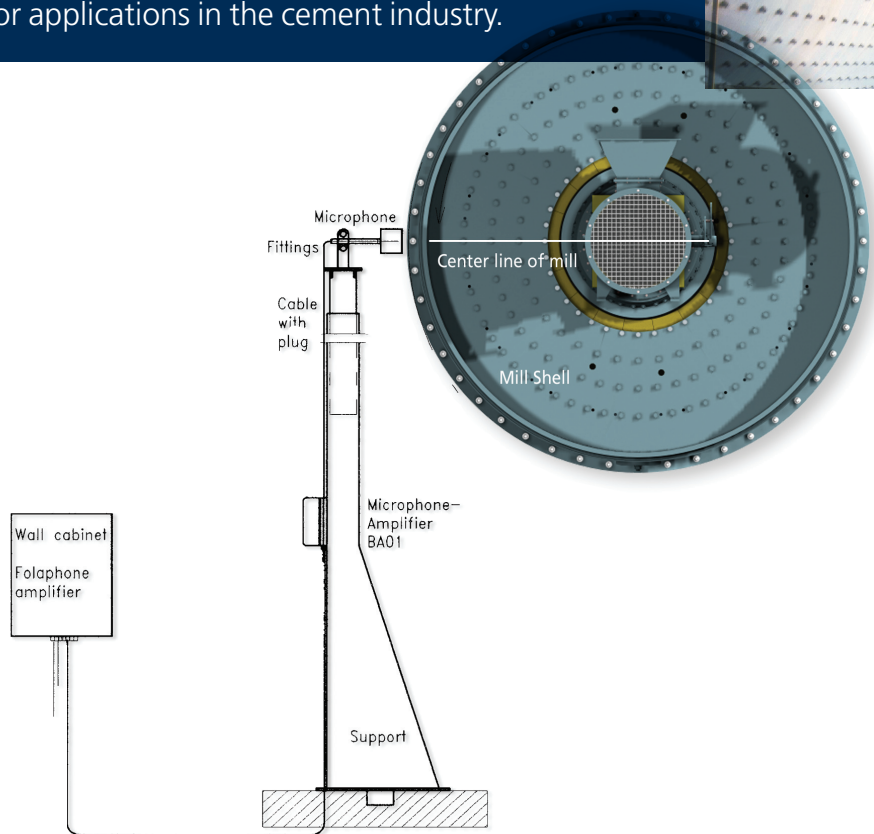

Application

The FLSmidth Automation Folaphone system is designed for monitoring and supervision of the material charge in a ball mill. The System is developed for applications in the cement industry.

Features

- On-line continues control of the filling charge of material
- Simple system - easy installation
- Low maintenance

Description

The Folaphone system comprises of:

- Magnetic microphone
- Microphone amplifier (two-wire transmitter)
- "Signal treatment" - wall cabinet with electronics for treatment of the Folaphone signal (optional)
- Support for mounting of the microphone (optional)

The purpose of the system is to report the variations in the load of material during mill operating, and (optionally) to generate alarms when the mill is being overfilled or insufficiently filled.

The Folaphone system consists of a measuring transducer, which transforms the mill shell vibrations (equal to mill sound/noise) into an electric signal.

When the measured sound intensity from the mill increases, it indicates that the material level in the mill is getting lower and vice-versa when the sound intensity decreases.

Mode of operation

The Folaphone system measures the "sound level" of the mill by means of the special Folaphone microphone and amplifier. The resulting output from the "microphone amplifier" is called the "sound level" signal.

The purpose of the signal treatment, in the wall cabinet, is to make a signal that is proportional to the material filling in the ball mill. The "sound level" signal is first damped and inverted, and then it is amplified and converted to an output signal proportional to the filling of the mill. The output signal from signal treatment can be used for recording of the variations in the material filling during mill operation. Alarms can be set in the signal treatment to give alarm when the mill is going to be overfilled or insufficiently filled. The output signal from the signal treatment can also be used with a kW signal from the elevator motor for automatic control of the mill feeding.

When the signal treatment is optional, it is possible to program these functions in a PLC with analog calculation possibilities.

The Folaphone can be used for control of mills in many control situations:

- Without return of material
- With return of material where the elevator motor kW signal is used as an indicator of the returned material
- With return of material where the amount of the returned material is measured directly
- Etc.

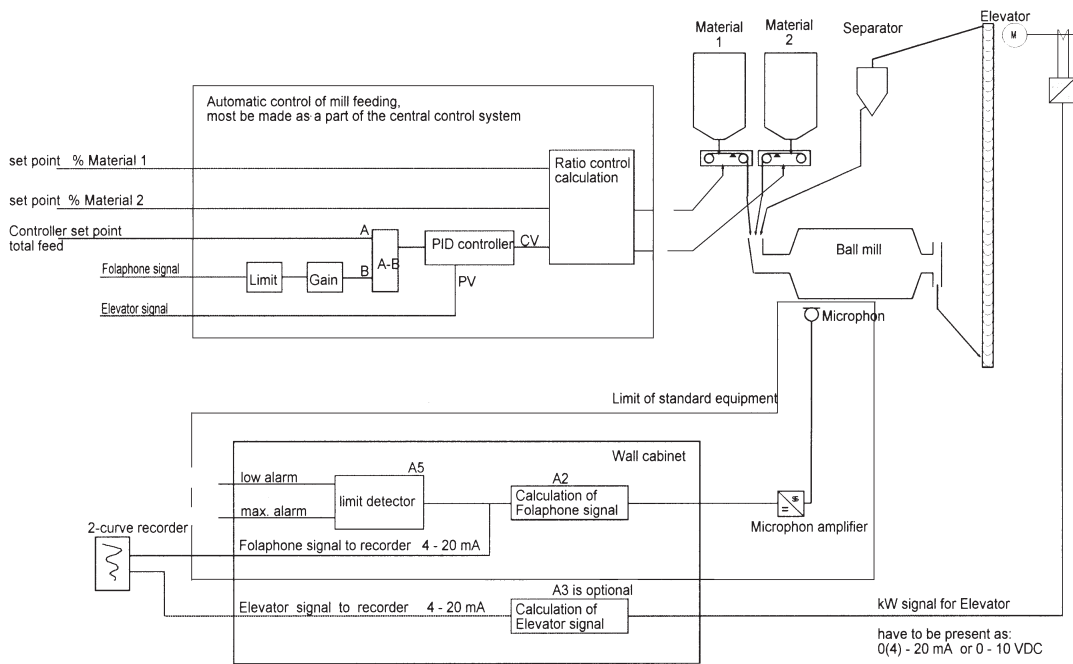

Example of folaphone elevator control feed to mill.

© FLSmidth A/S Automation. All rights reserved. ECS/ProcessExpert, ECS/CEMulator, ECS/PlantGuide, QCX/RoboLab, QCX/OnStream, ECS/CemScanner, ECS/ACESYS, ECS/ControlCenter, ACE/Woodware, ECS/SmartStation, ECS/StackGuide, QCX/Laboratory, QCX/AutoSampling, QCX/AutoPrep, QCX/BlendExpert, QCX/BlendMaster and Kilnlog are either registered trademarks or trademarks of FLSmidth A/S Automation in the United States and/or other countries. All other trademarks are property of their respective owners.

FLSmidth Automation reserves the right to change specifications without prior notice. Our brochure makes no offers, representations or warranties (express or implied), and information and data contained in this brochure are for general reference only and may change at any time. Please contact us for specific information or data that may relate to your interests.