

UMD™ Ultimate Mill Discharge slurry pump

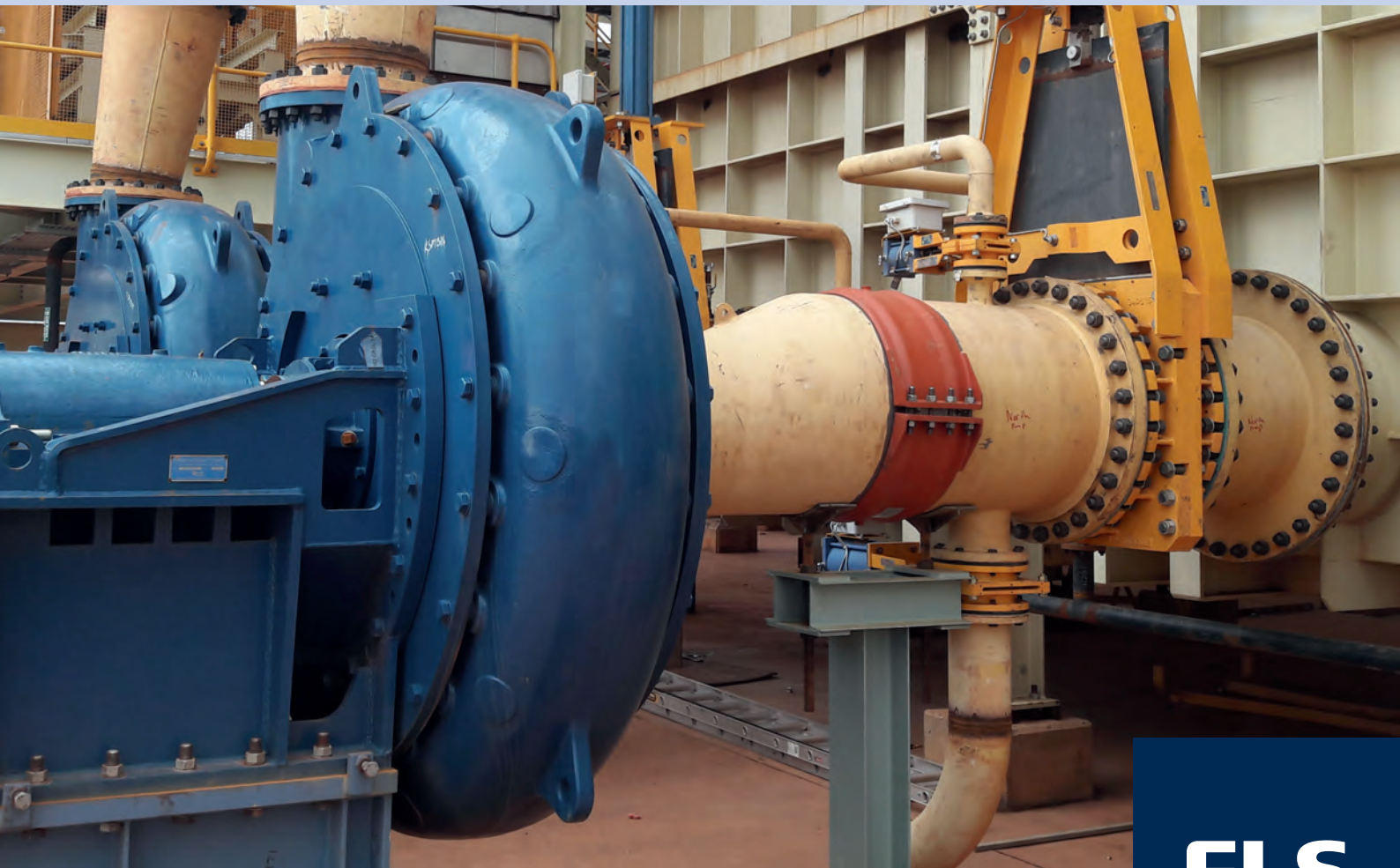

FLS

Heavy duty pump for tough abrasive slurries

Our KREBS UMD™ centrifugal slurry pump is designed to pump the discharge from hard rock grinding mills. The optimised, heavy duty design delivers the highest efficiency and even wear in the most abrasive applications.

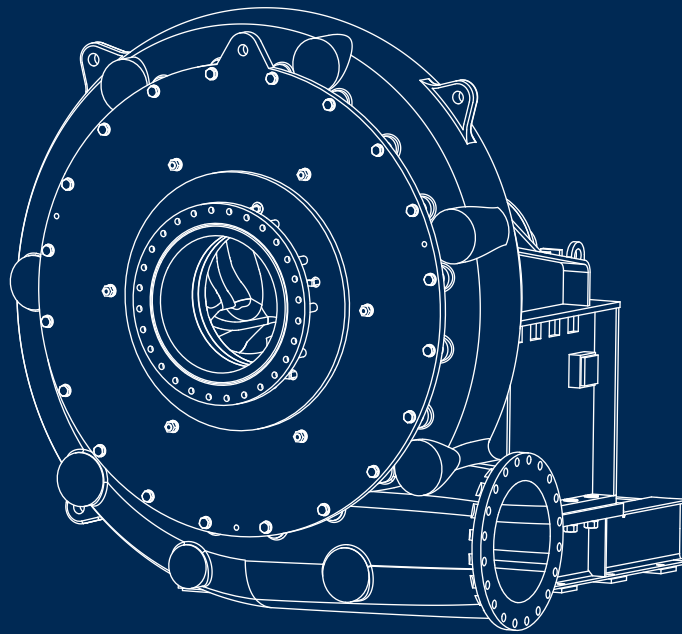

Benefits

- Even and predictable wear life for wet end parts
- Lowest cost-per-ton pumped
- Multiple material options for a wide range of applications
- 5-10% decrease in slurry power for the same flow and head
- Lower inventory requirements

Grind in your mill, not in your pump

The UMD pump integrates a superior hydraulic design with our patented suction-side sealing system to reduce grinding and recirculation, while maximising wear life and efficiency.

Even and predictable wear life for wet end parts

The UMD pump features our wear ring suction-side sealing system that solves both the grinding and recirculation problems within the pump. To stop recirculation, pumps without a wear ring must close the suction-side clearance either with a full-face suction liner adjustment or by adjusting the impeller to the suction liner. This can be effective when pumping fluids without solids; with slurries, however, the solids that become caught between the rotating impeller and static suction liner are crushed, consuming power and causing wear.

Our wear ring solution stops recirculation, while still allowing for a large gap between the impeller and suction liner—eliminating the grinding of solids and increasing the wear life by more than 50% when compared with other pumps.

5-10% decrease in power consumption for the same head and flow

Because the UMD maintains a constant operating speed and does not grind particles, the pump lasts longer and consumes 5 to 10% less slurry power.

Multiple material options for a wide range of applications

Our UMD is available in a variety of interchangeable elastomer, alloy and polyurethane liner materials. The UMD can handle a flow range from 200 to 90,000 GPM (50 to 20,000 m³/hr). High pressure and fully rubber lined split cased versions of the UMD pump are available for applications with wide flow ranges, corrosive agents and high discharge pressure requirements.

Lowest cost-per-ton pumped

Our UMD has been proven worldwide to reduce downtime, power and maintenance costs when compared to conventional pumps—in all, reducing your cost-per-ton pumped.

Lower inventory requirements

Many sites have pumps rotating in both left- and right-hand orientations. This requires keeping different casings, liners and impellers in stock. Our UMD has a symmetric casing, which means for either orientation, the same casing, suction liner, back liner and wear ring can be used (as shown below).

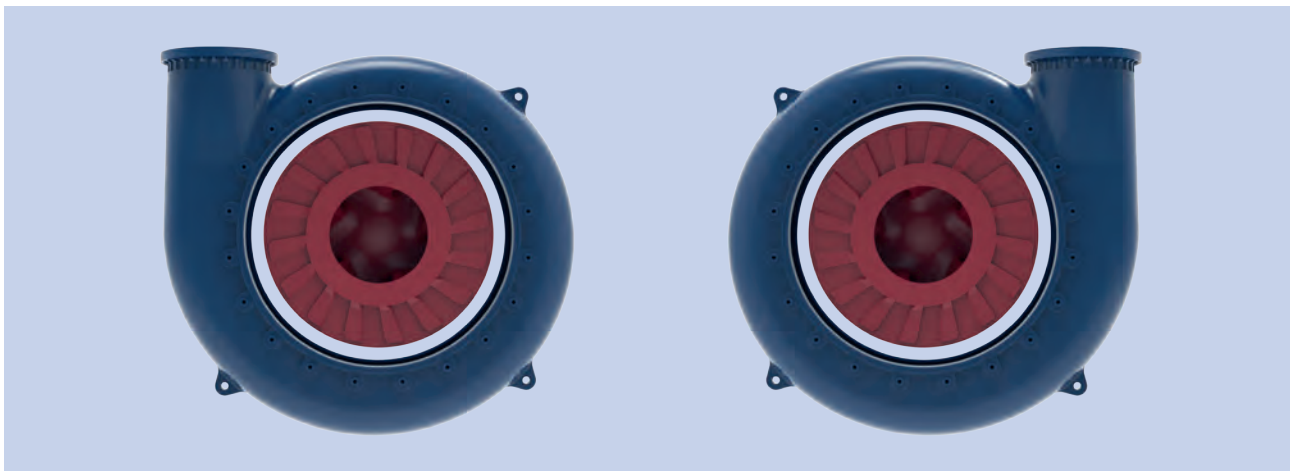

Lower your inventory requirements with our UMD symmetric casing design

Patented UMD designs

Longer wear life

Unique casing design

The UMD's large clearance between the casing and impeller creates a deep bed of slurry that acts as a buffer zone, shielding the casing from the direct impact of coarse solids. An enlarged cutwater clearance reduces turbulence to extend pump life.

Optimised impeller design

We have optimised the shape of the pumping vanes, increased the shroud diameter, and improved the shape of the expelling vanes to bring you the most hydraulically advanced impeller of its kind. The UMD impeller design reduces localised wear at the leading edges of the vanes to maintain efficiency and extend the wear life.

Oversized outer liners

Conventional pumps experience high wear rates around the outer diameter of the impeller due to the turbulent regime of fine solids. With this in mind, the UMD design incorporates oversized suction and back liners to contain the wear and protect the sides of the casing. Available in a variety of material options, the UMD puts the right liner material in the right place to provide 30-40% increased wear life over conventional pumps. Further, the design saves both money and maintenance time as the side liners are less expensive and easier to replace.

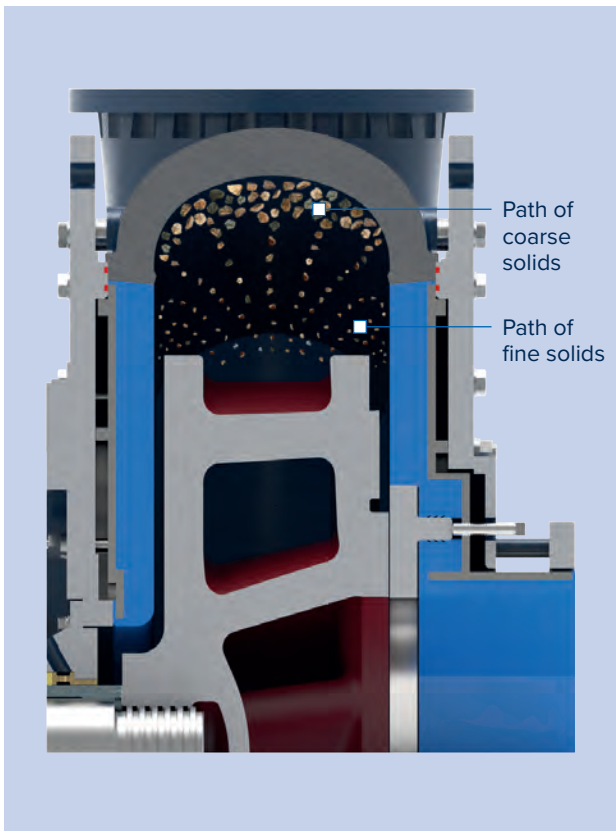

Wide clearances in the UMD create the deep bed of slurry that acts as a buffer zone to protect the casing

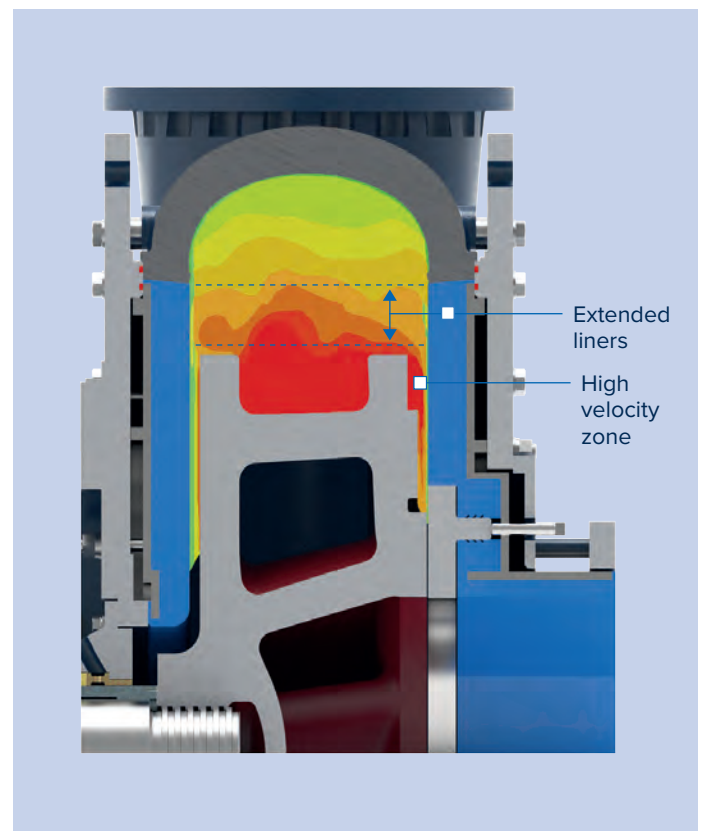

CFD analysis of velocity within an operating pump

KREBS® quick release Feature for quick and safe rebuilds

Even and predictable wear life for wet end parts

In mining operations, reducing the time spent on pump maintenance is critical because it directly impacts the bottom line. The concept of reducing downtime is similar to a professional auto race where the seconds spent changing tires during a pit stop are some of the most pivotal moments of the race.

Similar to swapping out worn tires, our quick release design allows you to quickly change out the worn wet end for a new module that's been fully assembled off site.

Our quick release feature provides:

- 50% reduction in pump rebuild time
- Modularization for safe and easy rebuilds
- Option for off-site maintenance with our wet end module exchange program

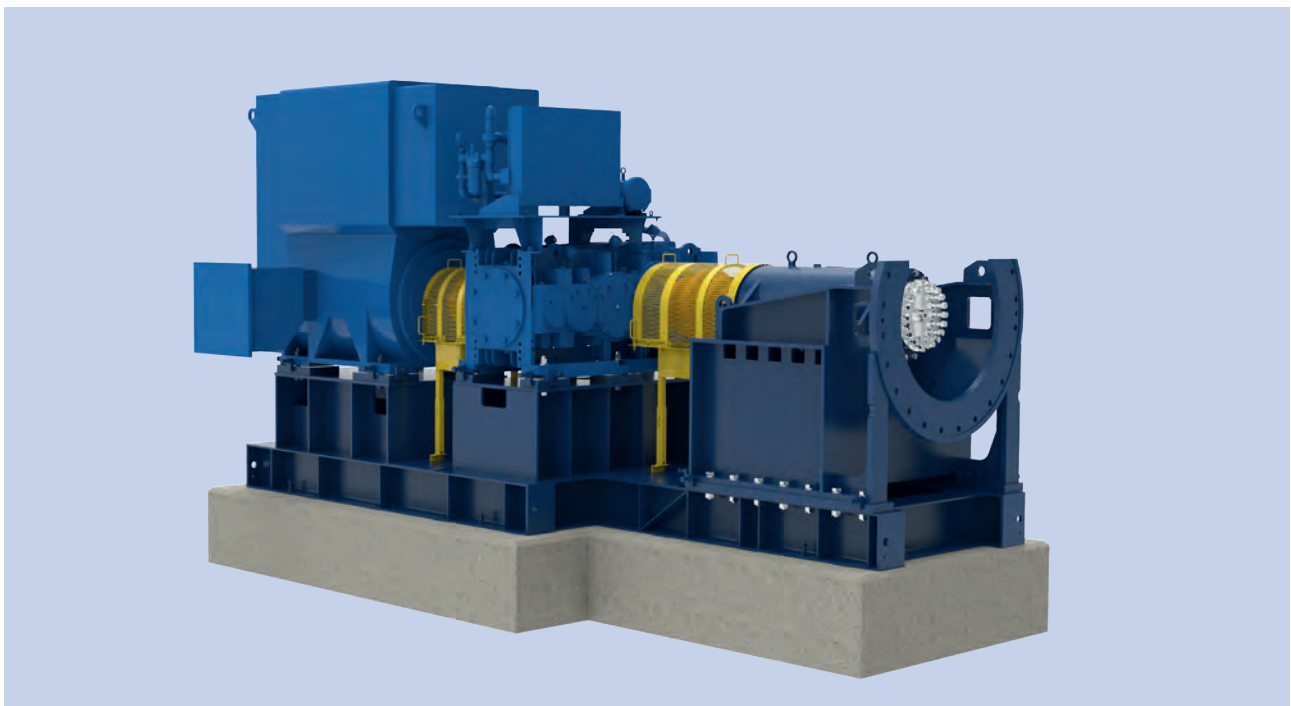

UMD™ unlined pump

Design features

Advantages of an unlined pump

- At least 20% reduced maintenance time
- Compact, space saving design
- Fewer components required
- Symmetric casing design allows for use of same casing, suction liner, back liner and wear ring for both left- and right-hand orientations

Adjustable wear ring

- Reduces suction-side recirculation
- Adjustable during operation
- Closes clearance at the impeller
- Maintains hydraulic performance
- Bearing assembly movement not required to adjust impeller clearances within the pump

Bearings that cannot be over-greased

- Pumping action of taper rollers discharges grease to the outside, preventing ingress of slurry and eliminating the possibility of failure due to over-greasing
- Increase the effective load span to improve life
- Heavy-duty shaft and taper roller bearings rated at 100,000 hours minimum of B10 life
- Larger pump sizes utilise dual taper roller bearings

Multiple material options

- Heavy-duty thick outer casing designed to handle impacts of large and abrasive solids
- Interchangeable elastomer, alloy and polyurethane liner material options available



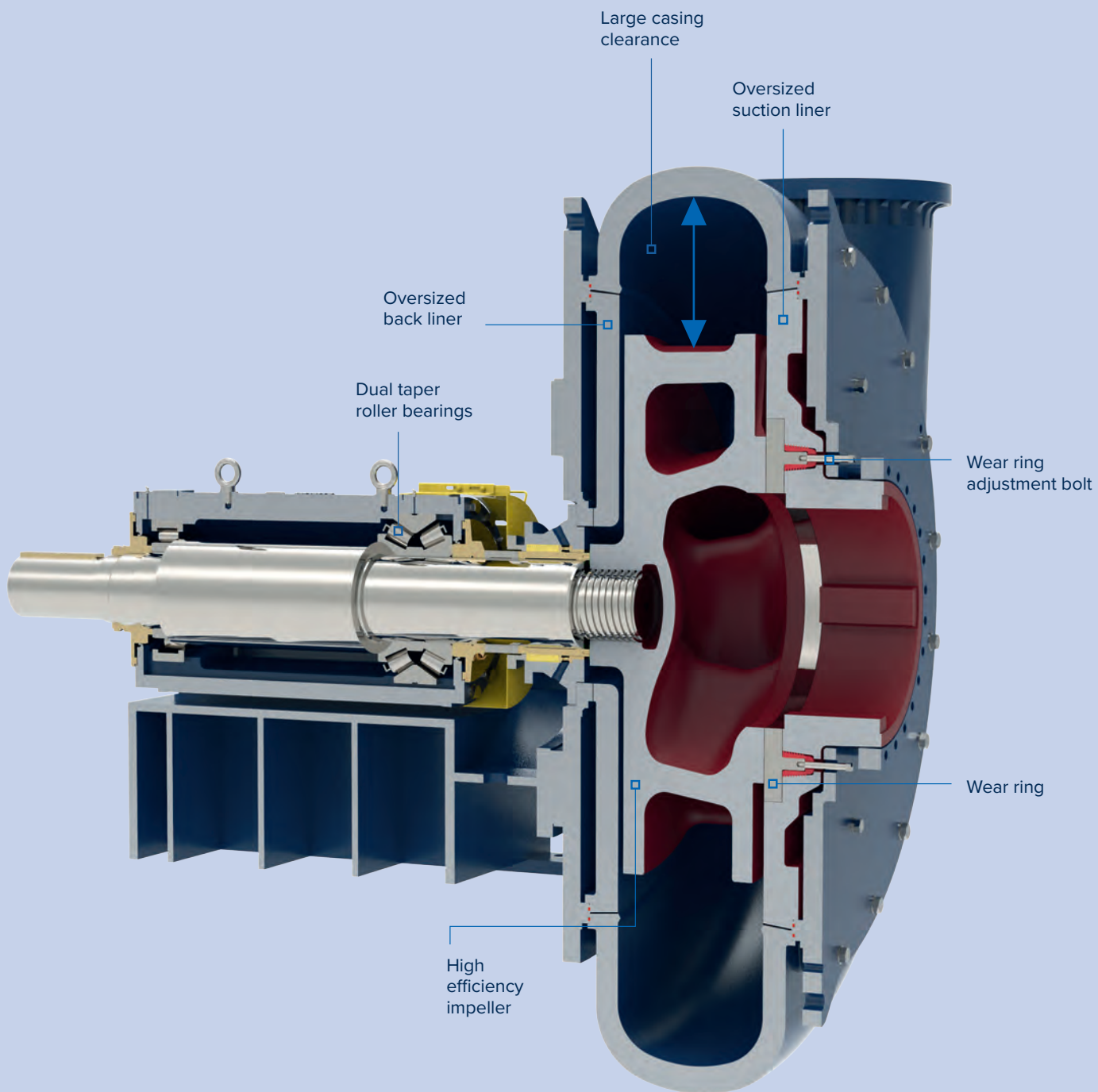

UMD™ -R

Split case rubber lined pump

Ideal for wide-ranging flows and corrosive duties

The UMD-R is a fully rubber lined, split case version of the UMD. With thick rubber liners available in a range of elastomer material options, the UMD-R is particularly suited for heavy-duty mill discharge applications with wide flow ranges and/or corrosive agents.

The UMD-R utilises the same suction liner assembly, impeller and back liner components as the UMD unlined pump range.

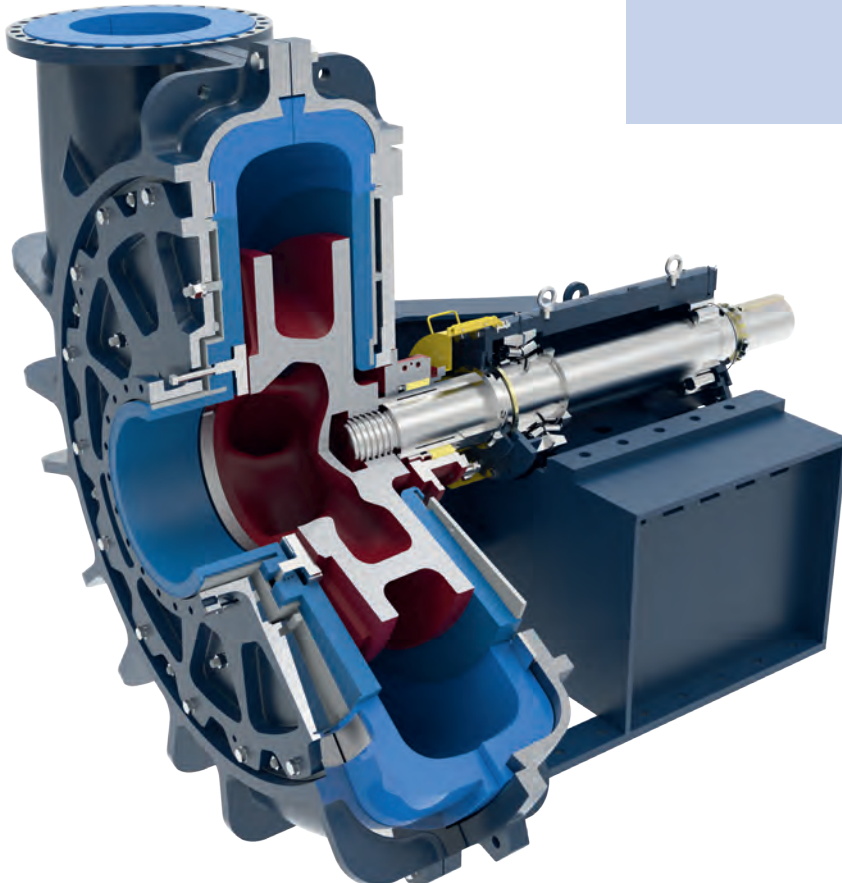
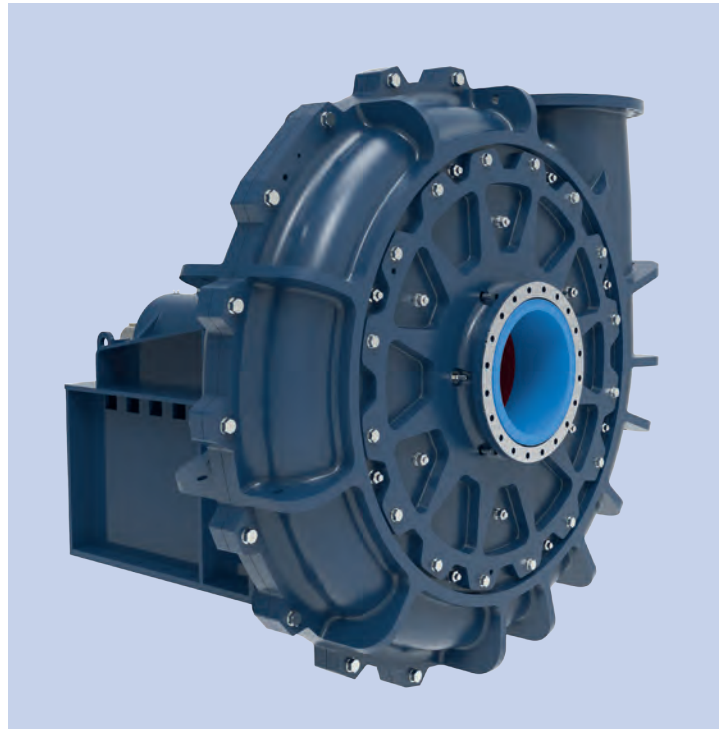

UMD™ - HP

High pressure pump

Ideal for multistage applications

The high-pressure version of the UMD is designed specifically for multistage, high-pressure coarse tailings and hydrotransport applications. Within the tie-bolt design outer casing halves, sits a large diameter impeller and a thick chrome iron casing with added rib reinforcement. Back and suction liners, available in a range of ultra-wear resistant materials, significantly extend the wear life in the most abrasive applications.

Safe and easy adjustment at high pressures

Conventional designs, which rely on full face suction liner adjustments, require special tools and extreme force to attempt to reduce recirculation. By contrast, our wear ring makes up a small cross-sectional area of the suction liner minimising the force required to adjust the wear ring when the pump is operating.

In fact, these adjustments can be performed by one person with a standard wrench. While competitors risk catastrophic failure from full face suction liner adjustments contacting the high velocity periphery of the impeller, wear ring adjustments occur close to the centre of the impeller where the velocity is low. As a result, wear ring adjustments on KREBS pumps provides the safest and easiest suction side sealing system, even at high pressures.

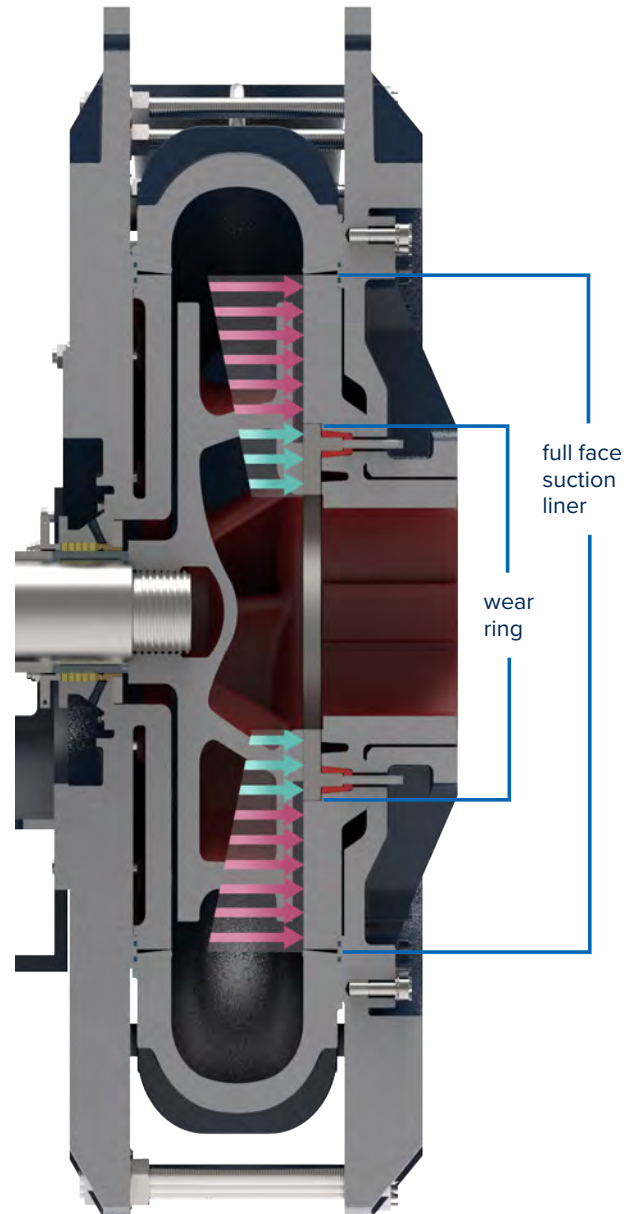
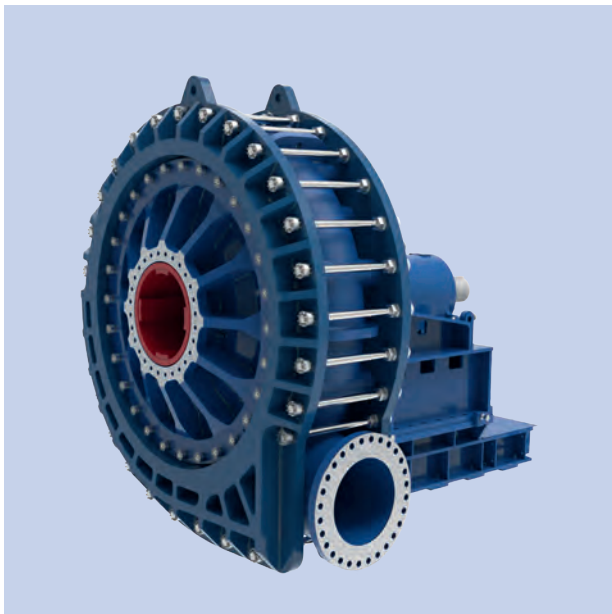

Force required to adjust a full face suction liner is exponentially greater than the force required to adjust our wear ring

low  high

Product range and applications

UMD™ size range

Imperial units (in)	Metric units (mm)
6 x 5	150 x 125
8 x 6	200 x 150
10 x 8	250 x 200
12 x 10	300 x 250
14 x 12	350 x 300
16 x 14	400 x 350
18 x 16	450 x 400
20 x 18	500 x 450
22 x 20	550 x 500
26 x 22	650 x 550
28 x 26	700 x 650
32 x 28	800 x 700
34 x 32	850 x 800
38 x 34	950 x 850

Mining Applications include:

- Mill discharge/primary cyclone feed
- Oil sands hydrotransport
- Hard rock tailings
- Coarse tailings
- Regrind cyclone feed
- Multistage applications
- High-flow applications
- Wide-flow applications
- Corrosive duties
- Other highly abrasive applications

Full Service Lab Testing

Our full-service lab provides performance testing and customer specific testing. The knowledge gained from the test work and slurry analysis help lay the foundation for successful projects. We also utilize this facility for product development test work to ensure we are always providing our customers with the highest quality and cutting-edge technology.

Pump Selection

Selection of the appropriate pump for a specific application is the work of an expert, as is the proper operation and maintenance of the pump when installed and in service. FLS offers this industry-leading pump expertise, assisting in selecting the most suitable pumps for our customer's specific needs.



Site Support

Once the pump is installed, our team of site support engineers closely monitors the pump's operation on-site, ensuring that it is consistently operating within the designated parameters. This is particularly important as mines and mineral processing plants are not static operations: they develop and change over time, which can result in pumps operating outside of their BEP zone, with negative impacts on performance, energy consumption, and wear rates.

A site support engineer will note any changes to the operating conditions and be able to recommend upgrades or changes to practice that will ensure the pump continues to deliver the best-possible performance. They can also offer training to mine personnel on the correct operation and maintenance, including how to properly adjust the wear ring.



Service Centers and Rebuilds

To guarantee top-notch products for our customer at every service centers worldwide, all pump assemblies are uniformly constructed with the same precision and quality. These service centers are strategically located around the world, allowing us to provide fast and efficient offsite rebuilds.

Condition Monitoring

FLS offers a variety of digital services including our Site-Connect mobile application and condition monitoring reports. Customer signal/sensor data is connected to FLS Cloud through our Field Agent box or through customer OSI-PI system. Advanced KPI's are then provided through our SiteConnect mobile application. Weekly insight reports look at performance and identify potential failure modes.

Aftermarket

By working closely with our customers, we ensure that our products are readily available whenever they are needed. From casting to finished painted parts, FLS has the equipment and expertise to deliver the best material options to our customers. Not only that, but our engineers are continually innovating to give our customer the best solutions.

FLS has a wide range of elastomers that can handle various chemicals, pH/concentrations, and temperatures ranges. Additionally, we offer proprietary high chrome irons specially designed to provide outstanding abrasion and/or corrosion resistance. Beyond that, in the most abrasive applications we offer tungsten carbide laser cladding to significantly extend the wear life. New to our material offering is our range of urethane liners capable of operating at higher tip speeds and able to withstand fine particle wear.

KREBS® PCV Regional Global Sales

FLSmidth Inc.

Tucson Operations
Tucson, AZ USA
Tel + 1 520 744 8200
krebs@flsmidth.com

FLSmidth Pty Ltd.

Welshpool
Western Australia
Tel: +61 8 6258 4800
krebsaustralia@flsmidth.com

FLSmidth - South Africa

Stormill, Randburg
South Africa
Tel: +27 0 10 210 4750
krebsafrica@flsmidth.com

Learn more about our
PCV product offerings

[KREBS® Slurry Pumps](#)

[KREBS® Cyclones](#)

[KREBS® Slurry Valves](#)

[KREBS® Vessels](#)

[KREBS® DeSanders](#)

FLSmidth GmbH Austria

Neusiedl am See, Austria
Tel: +43 2167 3345
krebseurope@flsmidth.com

FLSmidth - Chile

Santiago, Chile
Tel: +56 2 2463 8350
krebschile@flsmidth.com

Follow us here



flsmidth.com/linkedin



flsmidth.com/twitter



flsmidth.com/facebook



flsmidth.com/instagram



flsmidth.com/youtube

Contact us

FLSmidth A/S

2500 Valby
Denmark
Tel. +45 36 18 10 00
info@flsmidth.com

FLSmidth Inc.

Tucson Operations
Tucson, AZ 85743
USA
Tel + 1 520-744-8200
krebs@flsmidth.com



Copyright © 2023 FLSmidth A/S. All Rights Reserved. FLSmidth and FLS are (registered) trademarks of FLSmidth A/S. This brochure makes no offers, representations or warranties of any kind (express or implied), and information and data contained in this brochure are for general reference only and may change at any time. FLSmidth does not guarantee or make any representation regarding the use or the results of the information or the data provided in the brochure in terms of its correctness, accuracy, reliability or otherwise, and shall not be liable for any loss or damage of any kind incurred as a result of the use of the information or data provided in the brochure.