

HPGR / HPGR Pro

The next level in grinding

Sustainable and efficient grinding



FLS

Today's technology for today's mines

Our HPGR is flexible enough to be highly suitable for both brownfield expansions and greenfield installations. The wide variety of ways our customers are already using the machine shows just how helpful the technology is.



Key benefits

- Higher grinding efficiency compared to horizontal grinding mills
- Stabilizes grinding operations when faced with high ore variability
- Reduces the need for, and consumption of grinding media
- Micro-cracking in the product offers metallurgical benefits seen downstream

HPGR is the most efficient comminution product in grinding and milling

High and rising energy prices can make a real dent in your profitability. Bring down energy consumption and increase your overall efficiency with the HPGR Pro, our latest generation high pressure grinding roll.

HPGR Expertise

- 35+ years of experience supplying HPGR's to mining customers.
- More than 150 machines installed across all mining sectors.
- More machines treating true, hard rock ores than all others combined.
- Field-proven wear surfaces that set the industry expectations for all applications.
- High level of shop pre-assembly prior to shipping to ensure a smooth fit-up on site - optimising erection and commissioning efforts.

Sustainable benefits

- Micro-cracking in the HPGR product reduces downstream power requirements.
- Provides a more stable grinding operation for variable ores
- Reduces the need for, and consumption of grinding media and associated emissions in manufacturing grinding media

159 installed HPGR units by sector

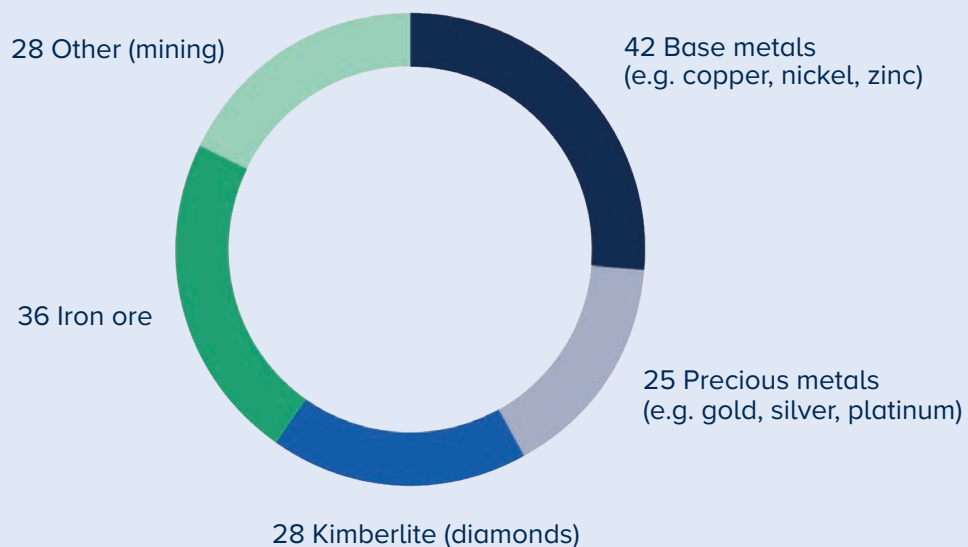

Component identification for HPGR Standard model

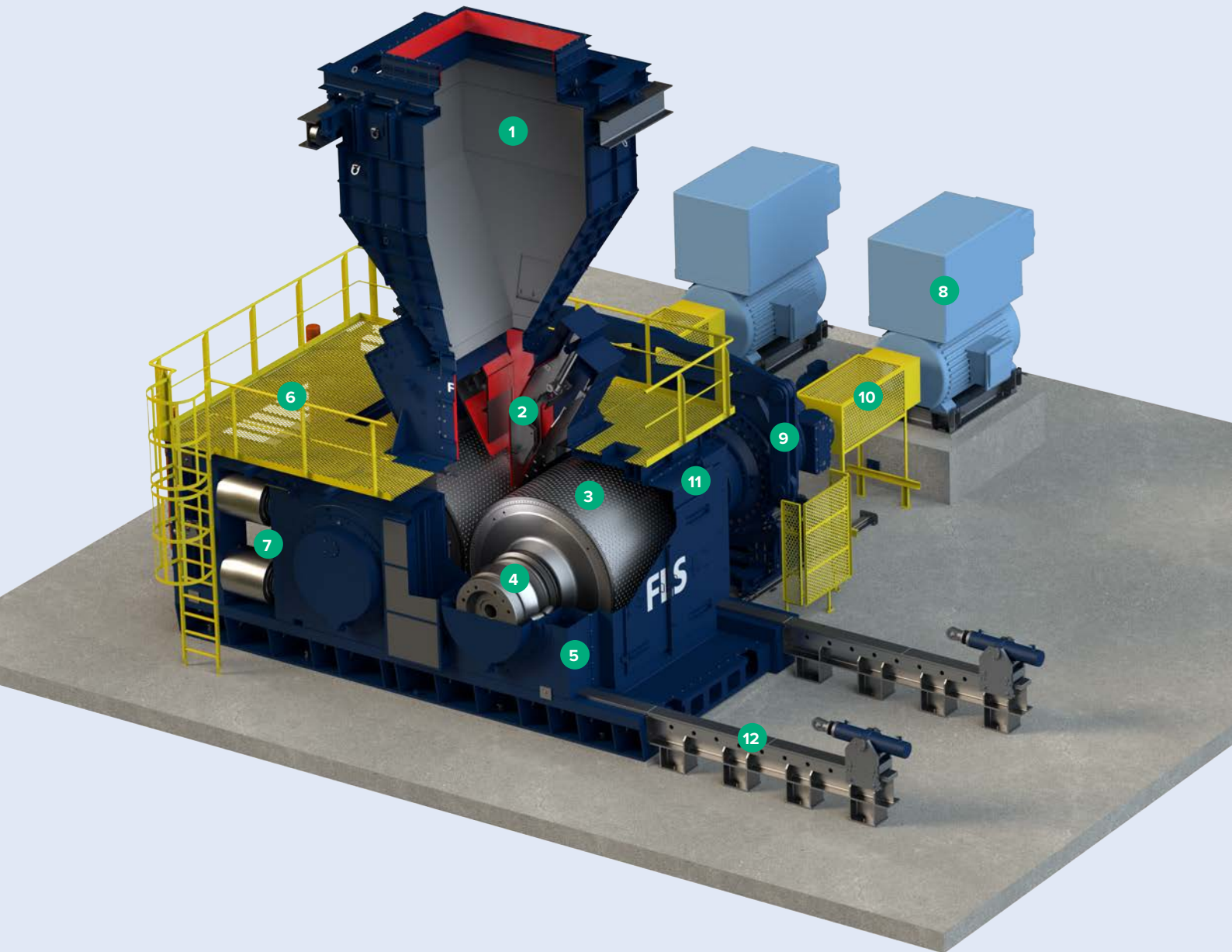

-
- | | | |
|-----------------------|-------------------------|---|
| 1. Feed chute (lined) | 5. Bearing block | 9. Gear reducers w/ torque arm assembly |
| 2. Feed control gate | 6. Maintenance platform | 10. Cardan shaft |
| 3. Studded Tire | 7. Hydraulic cylinders | 11. Dust enclosure w/ inspection doors |
| 4. Roll shaft | 8. Main drive motor | 12. Roll extraction frame |

Model sizes for HPGR Standard

| HPGR size | Type | Roll diameter [mm] | Roll width [mm] | Grinding force [kN] | Motor power [kW] | L [mm] | W [mm] | H [mm] |
|-----------|-------|--------------------|-----------------|---------------------|------------------|--------|--------|--------|
| PM0 | 9/7 | 950 | 650 | 2,700 | 2x220 | 3,240 | 1,860 | 3,800 |
| PM1 | 11/8 | 1,100 | 800 | 3,400 | 2x450 | 3,750 | 2,150 | 4,600 |
| PM3 | 14/8 | 1,400 | 800 | 4,300 | 2x500 | 3,735 | 2,164 | 5,400 |
| PM4 | 17/10 | 1,700 | 1,000 | 7,000 | 2x800 | 4,490 | 3,030 | 6,800 |
| PM5 | 20/10 | 2,000 | 1,000 | 8,600 | 2x1,600 | 5,950 | 3,000 | 7,500 |
| PM6 | 20/15 | 2,000 | 1,500 | 11,000 | 2x1,850 | 6,020 | 3,460 | 8,000 |
| PM7 | 20/17 | 2,000 | 1,650 | 13,500 | 2x2,500 | 6,550 | 3,640 | 8,800 |
| PM8 | 24/17 | 2,400 | 1,650 | 17,000 | 2x2,800 | 7,725 | 3,820 | 9,000 |
| PM9 | 26/18 | 2,600 | 1,750 | 20,000 | 2x3,400 | 8,500 | 4,150 | 9,700 |
| PM10 | 30/20 | 3,000 | 2,000 | 25,000 | 2x5,000 | 9,500 | 4,600 | 11,000 |

The next evolutionary step in our market leading HPGR technology is our HPGR Pro.

With next-gen features resulting in operational advantages, the HPGR Pro offers: higher throughput capacity, greater power efficiency, and longer wear life of rolls. For a new machine you can select all of our HPGR Standard models sizes (machine sizes 4 thru 10) in a HPGR Pro version. Your existing machine can be retrofitted with any and all of these features to transform it into a HPGR Pro.

HPGR Pro – features

- Rotating side-plates (RSPs)
- Mechanical skew limiter
- Stud detection system
- Oil lubrication system
- Advanced Machine Protection System (AMPS)

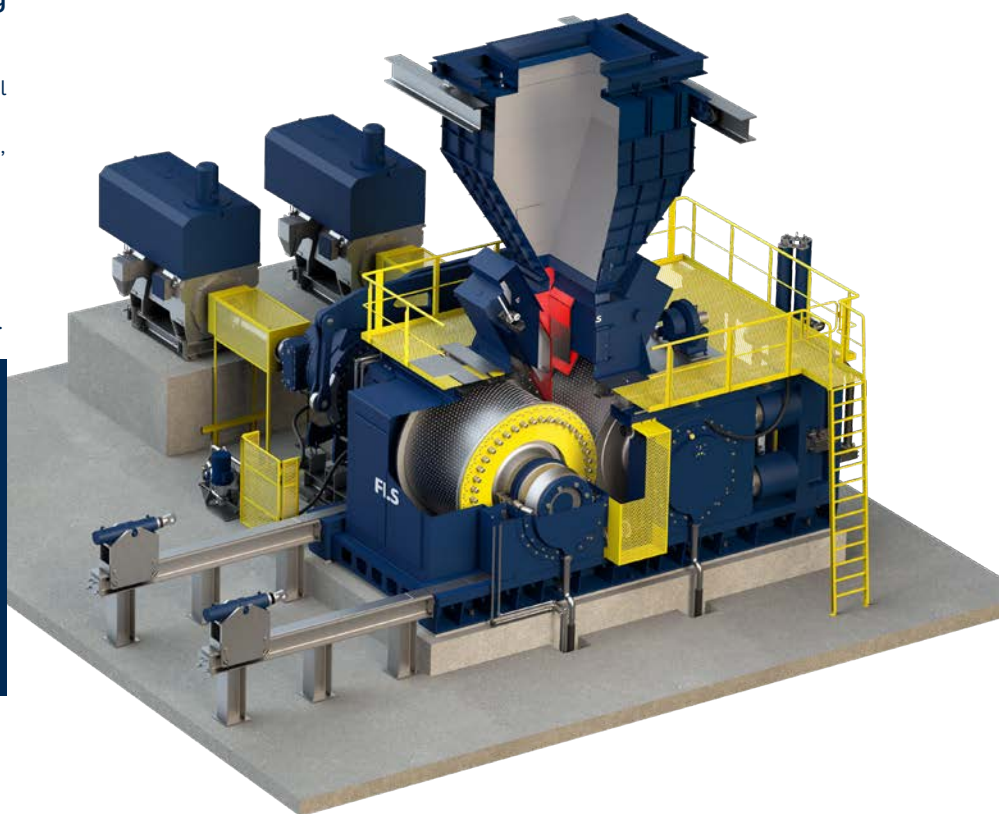

With our digitalized expertise comes greater throughput

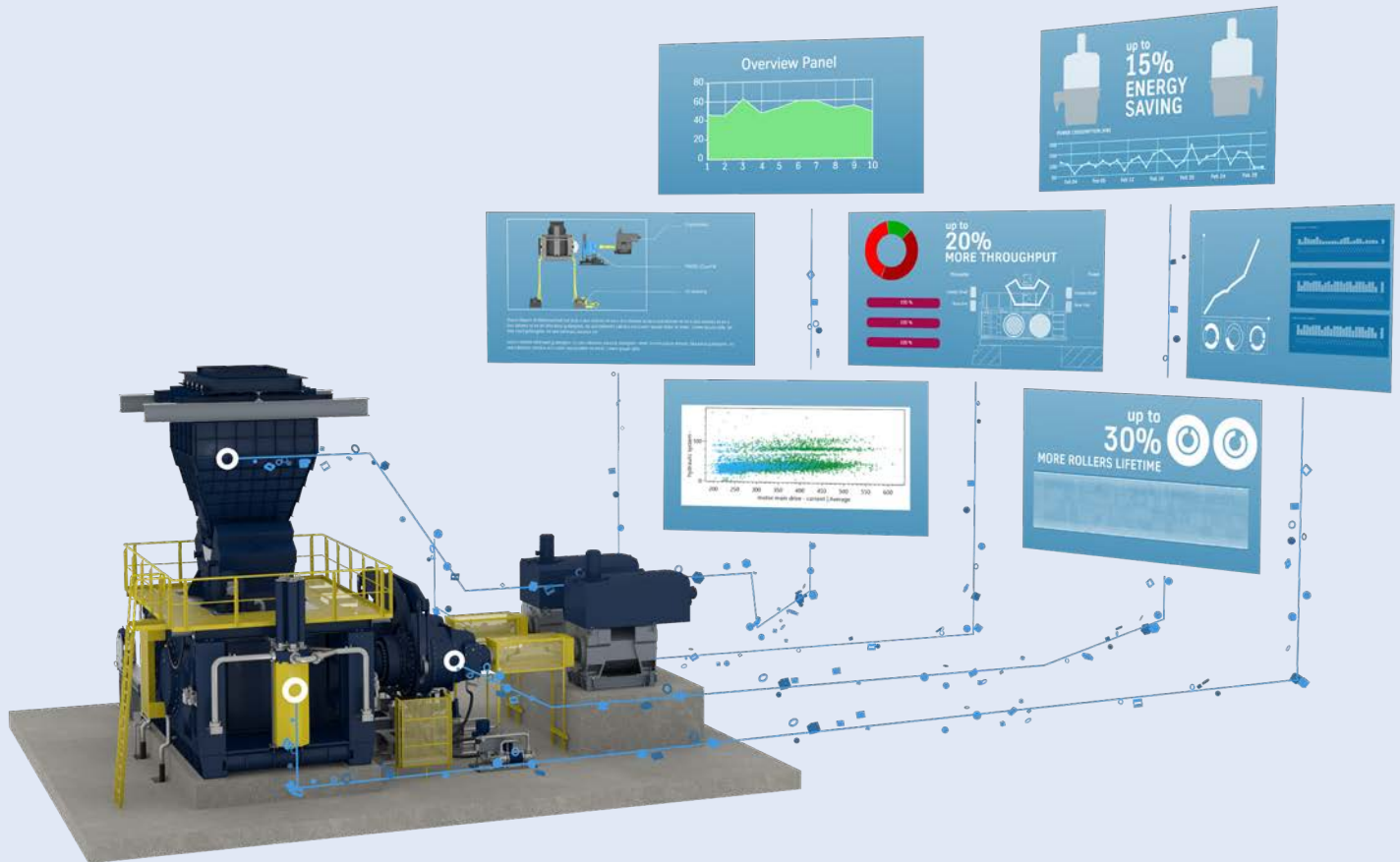

Continual optimisation via data analysis

Digital tools also allow us to optimise the operating point. We use modern sensor technology and our Advanced Machine Protection System to ensure the HPGR Pro automatically runs at the optimum operating point. This prevents overloading and vibrations, as well as ensuring optimised output.

What's more, as our specialists collect and process machine data, you can continually improve your HPGR Pro's operation and optimise throughput, energy consumption or machine availability in line with your specific targets. This data also enables fast diagnosis and root cause analysis in the event of a problem.

- Reporting and consulting services
- Predictive maintenance planning
- Optimum operating point with optimised output.

Are you ready to upgrade your HPGR?

We can equip your existing machine with the latest technical features from the HPGR Pro to make your machine fit for the future. Through our network of service centers and specialists we can support you anywhere in the world.

Rotating side plates for more throughput

Want more throughput without increasing the machine's footprint? The HPGR Pro makes that possible. The rotating side-plates on the fixed grinding rolls enable improved material feed and up to **20% more throughput** than conventional HPGRs. What's more, the machine's specific **energy consumption is reduced by up to 15%**.

At the same time, the uniform pressure profile in the grinding gap results in better grinding and more even roll wear. This **prolongs the service life of the rolls by up to 30%**. Through reducing the so-called bathtub effect the rolls need to be replaced less frequently – and your HPGR Pro will run longer with fewer downtimes.



Rolls with side plate upgrade

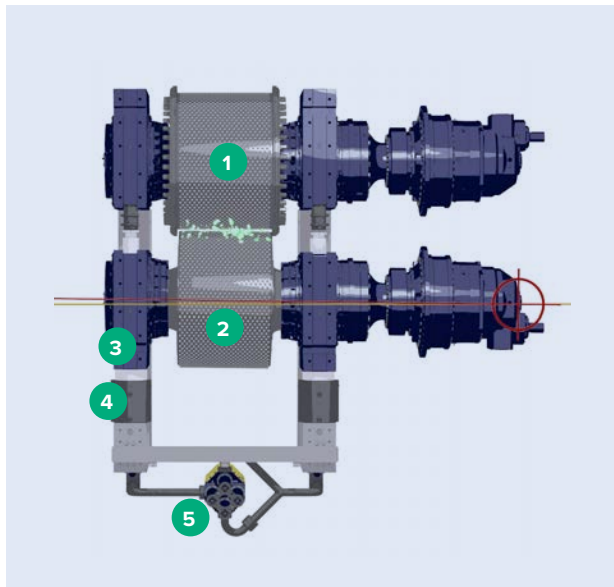

Controlled mechanical skew limitation

A certain amount of roll skew is beneficial because it ensures uniform grinding. The new and unique controlled mechanical skew limitation in the HPGR Pro allows skew but prevents excessive skew. Damage, which might be caused by excessive skew, is therefore prevented, even in case of an emergency or operational error. This makes the operation safer and avoids unscheduled downtimes.

- Maximum machine availability – even in case of an emergency or operational error
- Improves safety and reduces downtime
- Improved product quality

1. Fixed roll
2. Moveable roll
3. Bearing blocks
4. Hydraulic cylinders
5. Mechanical skew limiter

Upgrades that provide productivity and safety

Oil lubrication for increased availability

The HPGR Pro rolls are lubricated with oil and not grease. This allows the HPGR to operate at higher press forces (as needed to produce finer product size) without excessive heating of the bearings. Optimised bearing seals, oil quality monitoring, and continual filtering also reduce contamination and environmental impact. In addition, continual filtering enables the oil to be used for longer periods of time.

- Longer nominal service life of the bearings as per ISO 281
- Lower OPEX costs through reduced lubricant consumption
- Reduced environmental impact.

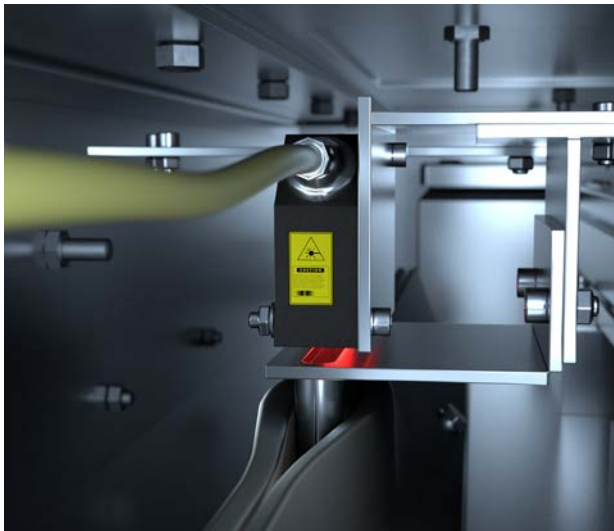
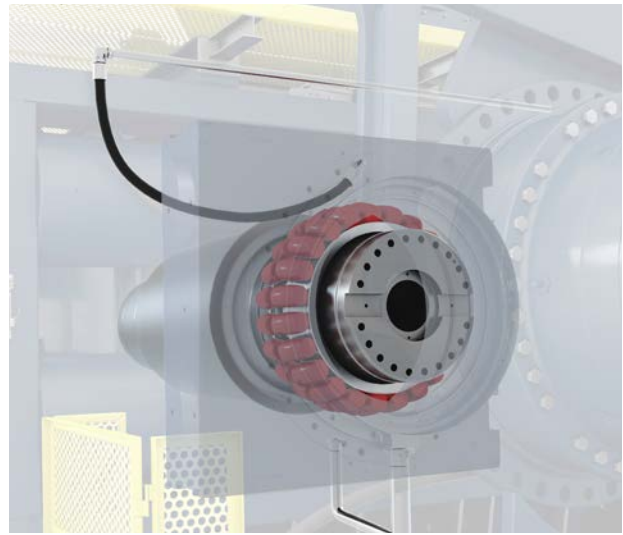

Stud detection system for on-line monitoring of the wear surfaces

The availability of the HPGR Pro is increased even further through our unique stud detection system. While the HPGR is operating, the surface of the rolls are automatically monitored and measured by a laser. So you are constantly informed about the state of the studs and the rolls. In this way, the stud detection system can predict the best possible time for roll replacement. And you no longer need to stop the HPGR as a precautionary measure, which saves you valuable time and money. An intelligent algorithm detects missing / broken studs or edge blocks. The defects are displayed within the phantom image. The scan function offers the possibility to measure the roll surface. FLS advanced algorithm calculates the wear of the roll to the exact mm.

Service capabilities. A global strategy

A realistic and effective service strategy needs to be part of the supply

In the history of HPGR in mining nobody has more experience in roll supply and servicing major components than us. With service centers strategically placed around the world, we are fully equipped to address the many challenges of supplying and supporting HPGRs – sometimes in very remote locations.

Let us be your logistics partner

Given the unique rebuild requirements of the HPGR wear surfaces, let us help you design a service solution catered to the specific needs of your project and location:

- What are the dimensions and mass of the largest maintenance components?
- What is the best plan for optimizing the roll service?
- Where to disassemble and what parts to ship?
- How best to minimize downtime and shipping?
- What other HPGR components should be scheduled for servicing?

Services available

- Fabrication & Heavy Precision Machining
- Bearing & Gearbox Reconditioning
- Replacement Parts
- Equipment Refurbishment
- HPGR Sub-assembly Manufacturing
- Installation & Commissioning
- Site Services (including Inspection)
- Training of Operating & Maintenance Staff
- Labor for Hire



Service contracts

Put your HPGR service concerns to rest by allowing us to detail a service contract that will help you to accomplish your OPEX goals without upsetting your operating targets. We are very experienced in all types of HPGR services and will provide options to discuss with the ultimate goal of producing a unique service execution catered to your project.

Please contact your local FLS representative to set up a meeting to discuss in further detail.



Primary grinding

HPGRs add efficiency to the primary grinding circuit for highly competent and complex ore bodies.

Over the last decade many customers have chosen HPGRs for primary grinding ahead of ball mills where they would have traditionally used SAG mills. Ore complexity, ore hardness, rising electrical costs and the need to stabilize the downstream process are just some of the reasons that more people are choosing HPGRs.

HPGR product has micro-cracked particles which weakens the boundaries and lowers the Bond work index. This reduces the amount of ball milling power required downstream.

With a reduced load for the ball mills, you get a substantial reduction in required motor power, lowered steel ball consumption and increased grinding efficiency. The change from a SAG mill to an HPGR in primary grinding results in a lower overall power consumption the comminution circuit.

In comparison to using staged crushing as ball mill feed preparation, replacing the tertiary circuit with an HPGR frees up ball mill capacity (or reduces the size of the ball mills and grinding media consumption). Three factors contribute to this; HPGR product is finer than conventional crushers meaning that a percentage of the discharge stream is already of final product fineness, the Bond work index is reduced due to micro-cracking, and the design feed size to the ball mill is lowered and reduces the amount of ball milling power required downstream.

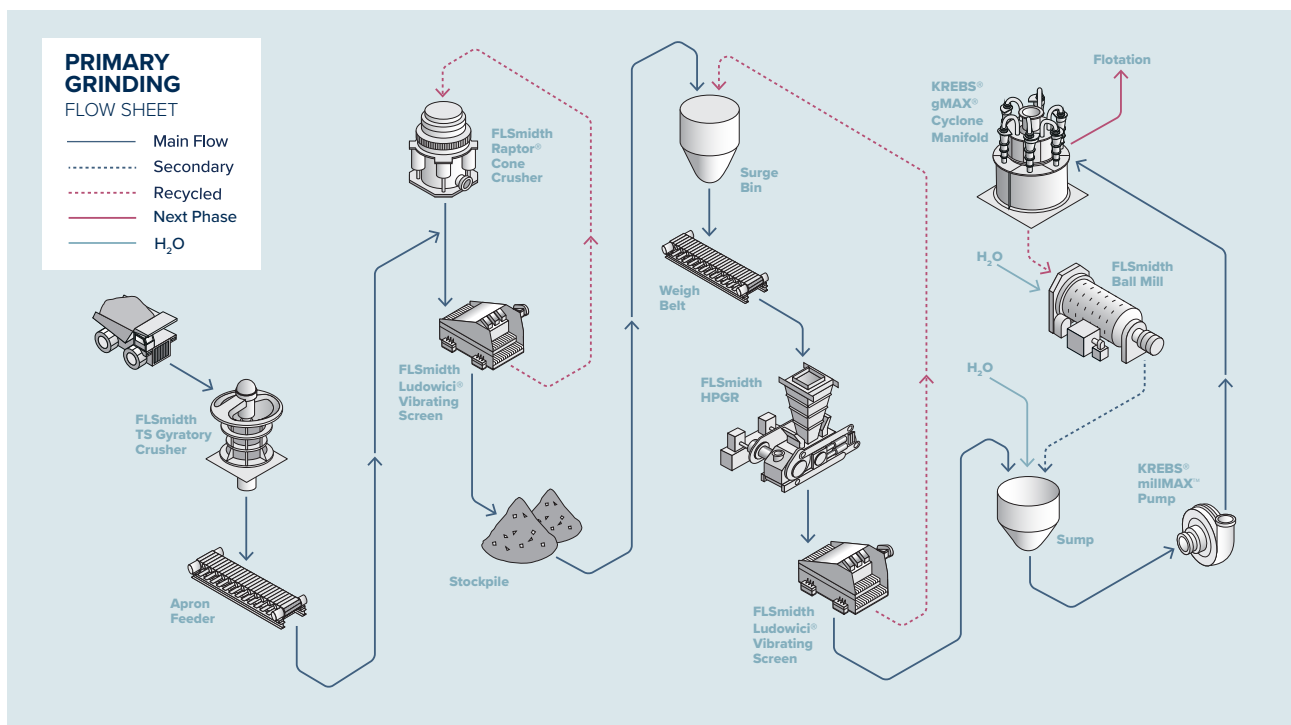

Heap leaching

If higher recoveries and faster leach kinetics are important to you, HPGR should be a consideration for your heap leach flowsheet.

The micro-cracking in HPGR product lends itself nicely to the heap leaching process. Cracking and cleaving along the particle grain lines, and the weakening of the rock structure increases exposure to the valuable ore particles, which enhances leaching kinetics. With this, you get faster leaching and higher recoveries compared to stage crushing alone. HPGR inclusion in heap leaching can be a viable retrofit to existing operations as well as for original plant designs.

HPGR flowsheet considerations for open circuit, closed circuit (with screen), or edge-recycling provide flexibility in the design to meet the particle size distribution needed to optimise your heap leach operation. Optimising the leaching process also lowers the amount of leaching solution that is required over the life of the mine.

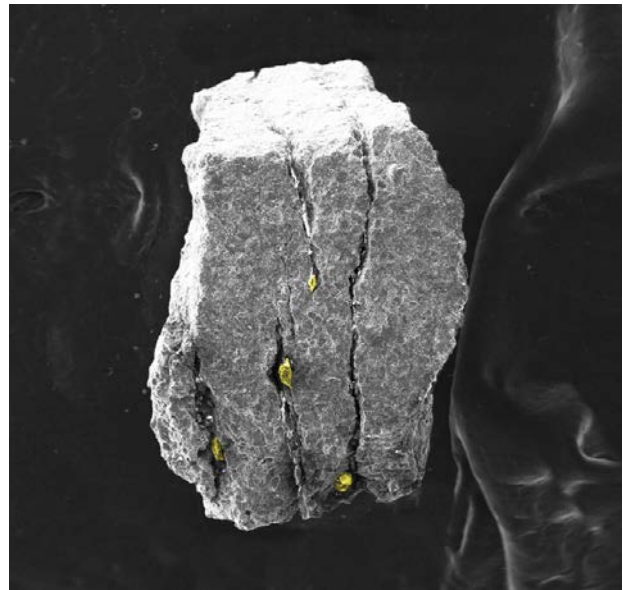

Lab photo of micro-cracked particle.

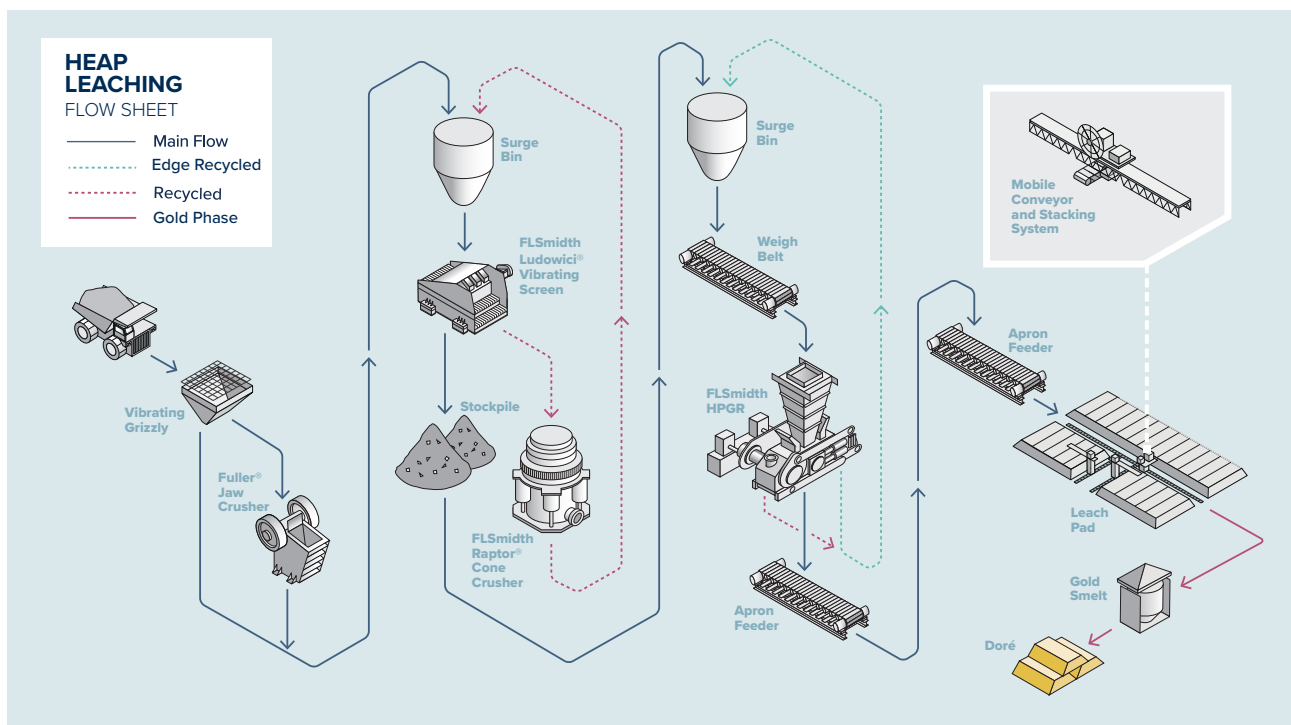

Pebble crushing

Our HPGR is great at de-bottlenecking your problematic pebble circuit.

You know how easy it is for hard pebbles to get caught in circulation, small enough to escape the mills but too large to make it through your screening process. Sending these pebbles back to the SAG mill until they are adequately sized works for softer ores. Harder, more competent ores, however, can result in crushed pebbles that continually circulate. Circulating pebbles eventually rob your SAG mill of volume and create an operational bottleneck.

Instead of feeling trapped by the conventional solution of constant recirculation, you can use our HPGR to leave the cycle behind. Our solution is to crush the pebbles with a cone crusher and then feed them to an HPGR. This arrangement will crush the pebbles enough that that you can feed the product directly into the ball mill sump. The change balances your circuit by increasing the available volume of your existing SAG mill and maximizing capacity of your ball mills.



Optionally, the process can be simplified by operating the HPGR in an open circuit and directing the discharge stream back to the SAG mill in-feed.

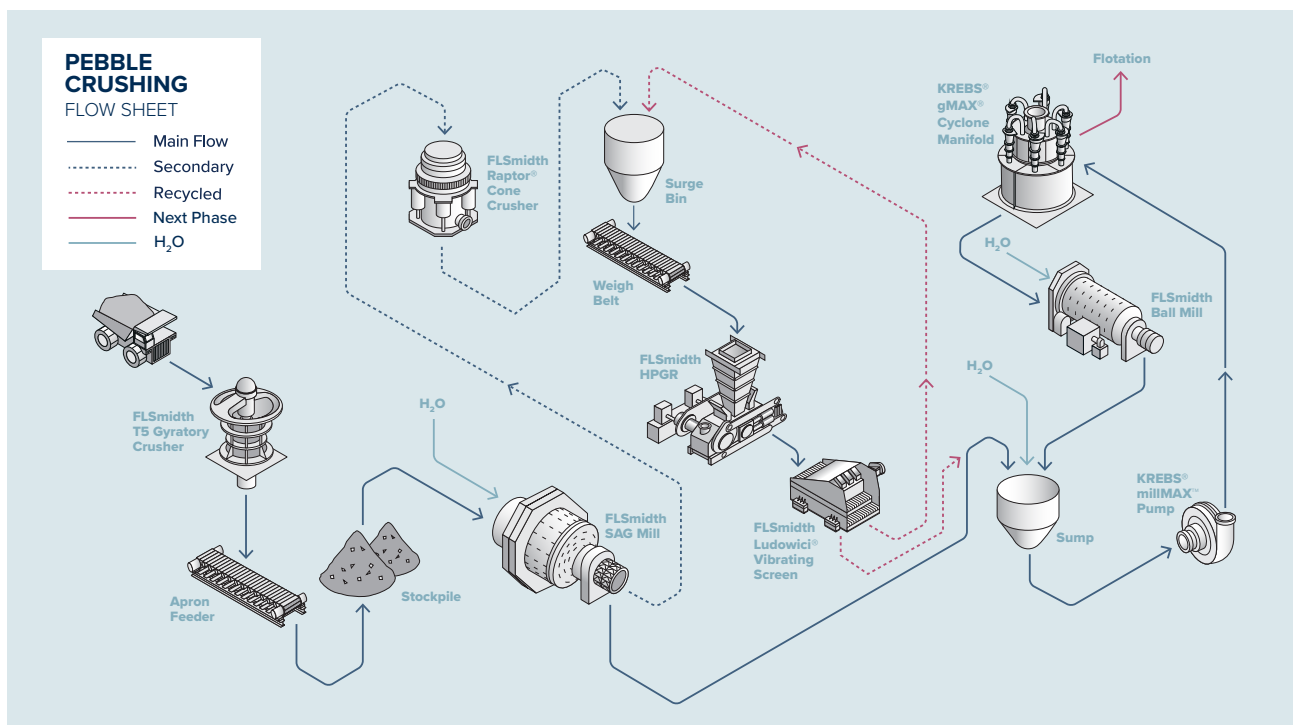

Finish grinding

The future of mining is dry comminution circuits that minimise wasted power, water consumption and carbon production.

This circuit also provides downstream benefits:

- The consumption of grinding media is eliminated.
- The finished, ground material can be immediately stored, creating a buffer and allowing the downstream plant to be fed at a consistent rate.
- Air separators provide a product with a narrower particle size distribution.

With more than 125 years of experience and over 1,500 dry classification systems installed, we are the world leader in dry process technology. We have a large selection of both static and dynamic classifiers to suit your project needs, including the best available air classifier in the industry.



SEPAX® Separator

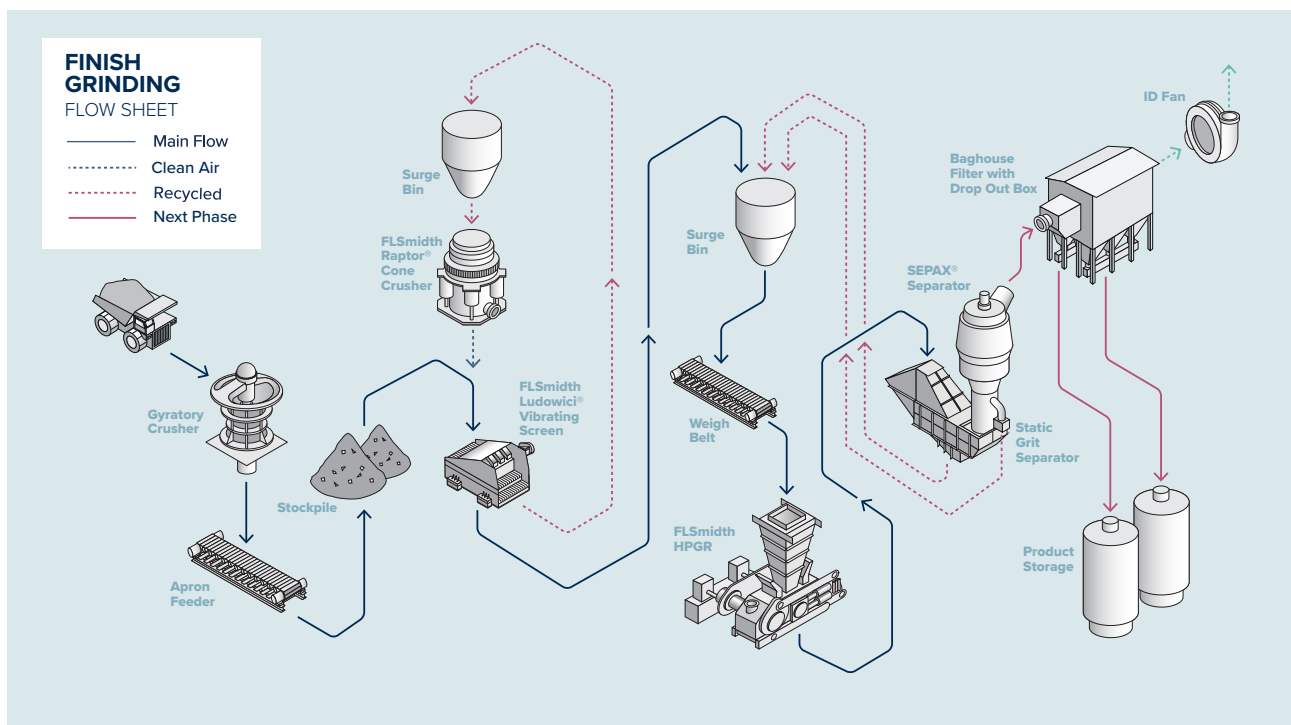

Lab testing capabilities. HPGR and beyond

All successful HPGR projects start out with testing

Unlike traditional comminution tests that are used for sizing horizontal grinding mills and fixed-gap crushers, material needs to be run through a semi-industrial sized HPGR in order to confirm; unit sizing, power requirements, and overall suitability for applying this technology. FLS uses several different testing units for specific purposes located around the world.



ATWAL

Requiring at 50-100 kg sample per test, ATWAL is the industry standard for HPGR abrasion testing. Results from this testing have correlated very well with predictive wear life of the rolls. Maximum feed size is 3.2 mm.

More than just machines!

Our testing procedures, analysis, and reporting are backed by more than 35 years of testing and supplying HPGRs across all mining sectors. Combine this with our experience as a full flowsheet provider and we would argue that there is nobody better placed to meet your project requirements:

- All types of HPGR testing
 - including finish grind with air classifier
- Traditional crushing & grinding tests
- Mineralogical & analytical testing
- Downstream metallurgy
- Liquid/solids separation



LABWAL

Requiring only a 15-30 kg sample per test, the LABWAL is a bench scale unit used for scoping tests. This can be useful for early indications on HPGR suitability. Throughput rate on the LABWAL is 3-6 MTPH and maximum feed size is 11.2 mm.

Pilot plant testing

PILOTWAL and MAGRO

Sizing tests and pilot plants

Our PILOTWAL and MAGRO units produce test results that are needed to confirm HPGR sizing and power requirements. Also, the machines are perfect for pilot plant opportunities where continuous testing of material can be useful for:

- Proof of concept
- Process warranties
- Circuit design
- Others



PILOTWAL

ø0.5m × 0.3m

10-25 MTPH

Feed size = 16 mm



MAGRO

ø0.95m × 0.35m

20-100 MTPH

Feed size = 31 mm

Follow us here



flsmidth.com/linkedin



flsmidth.com/twitter



flsmidth.com/facebook



flsmidth.com/instagram



flsmidth.com/youtube

Contact us

FLSmidth A/S

Vigerslev Allé 77
2500 Valby
Denmark

Tel. +45 36 18 10 00
Fax +45 36 30 18 20
info@flsmidth.com



flsmidth.eco/contact

Copyright © 2022 FLSmidth A/S.
All Rights Reserved. FLSmidth is a
(registered trademark) of FLSmidth
A/S. This brochure makes no offers,
representations or warranties
(express or implied), and information
and data contained in this brochure
are for general reference only and
may change at any time.