

Excel Premium Components

EXCELLENCE
SINCE 1929

GP Series® Cone Crushers

G8™ | G11™ | G12™ | G15™ | GP100™ | GP200™
GP300™ | GP500™ | GP550™

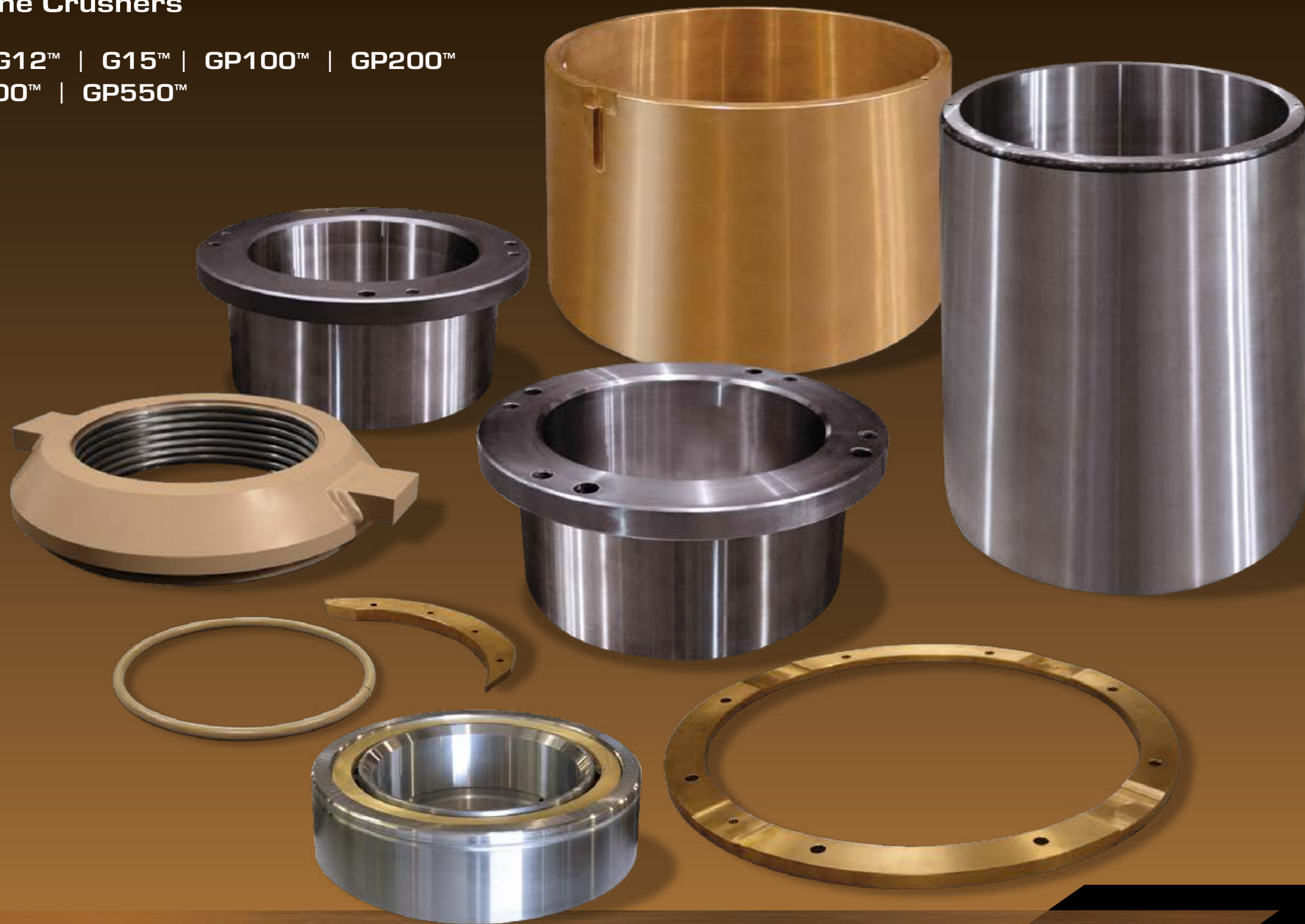

EXCEL
FOUNDRY
& MACHINE

Excel Premium Components

GP Series® Cone Crushers

G8™ | G11™ | G12™ | G15™ | GP100™ | GP200™ | GP300™ | GP500™ | GP550™



UPPER FRAME ASSEMBLY

- Top Bearing Cover
- Upper Frame Arm Guard
- Top Bearing
- Upper Frame
- Upper Frame Protection Plate

INTERMEDIATE FRAME ASSEMBLY

- Intermediate Frame
- Concaves
- Concave Mounting Bolt
- Jacking Bolt

LOWER FRAME ASSEMBLY

- Frame Bushing
- Lower Frame Arm Guard
- Piston Guide
- Lower Frame

STEP PLATE ASSEMBLY

- Upper Thrust Bearing Plate
- Thrust Bearing Plate
- Piston Seal
- Lower Thrust Bearing Plate

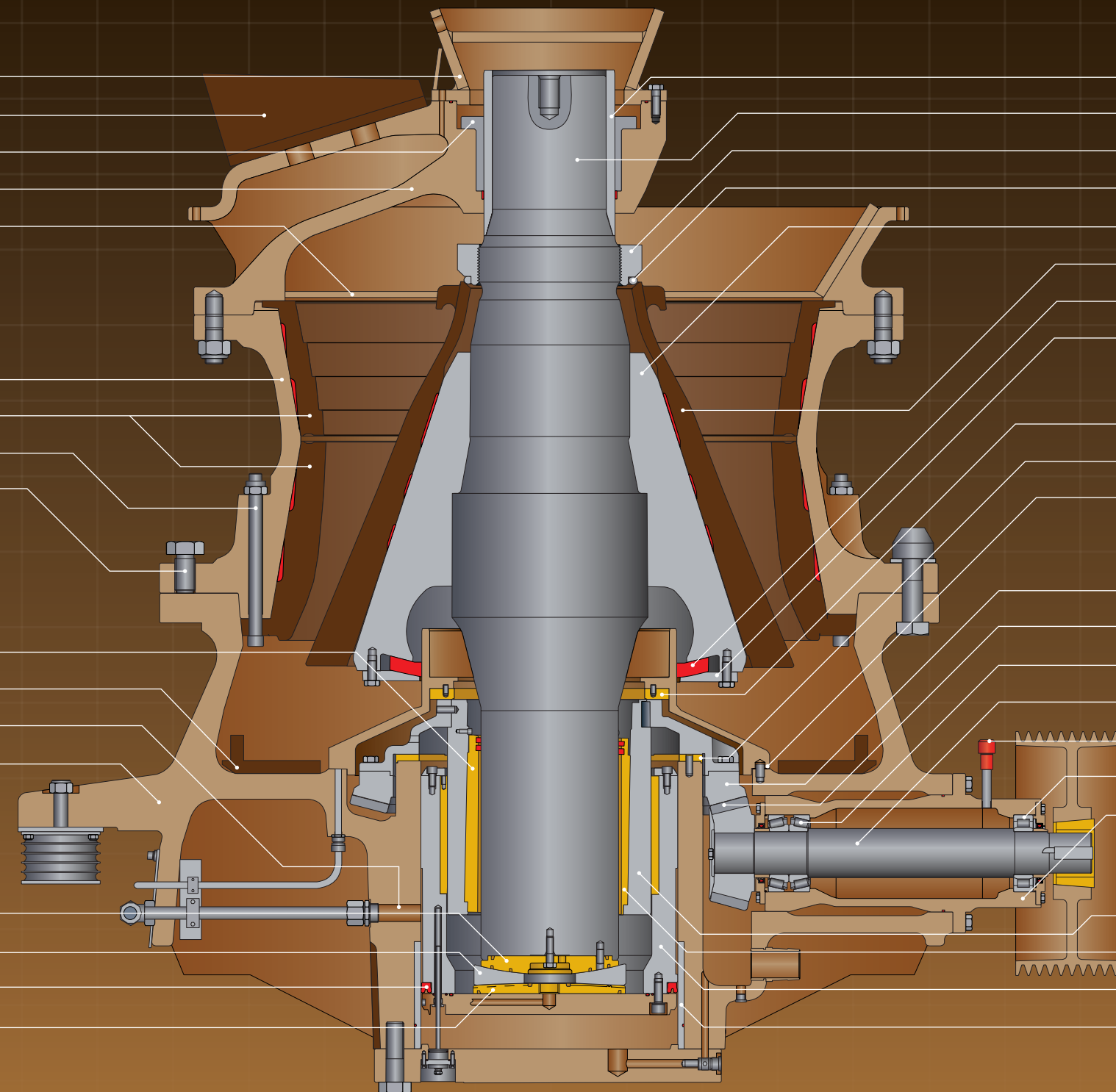

MAINSHAFT ASSEMBLY

- Mainshaft Protecting Sleeve
- Mainshaft
- Mantle Locking Nut
- Torch Ring
- Head
- Mantle
- Dust Seal
- Slide Ring

ADDITIONAL COMPONENTS

- Upper Thrust Bearing
- Lower Thrust Bearing
- Slip Ring

COUNTERSHAFT ASSEMBLY

- Gear
- Pinion
- Roller Bearings
- Countershaft
- Breather
- Roller Bearing
- Countershaft Housing

ECCENTRIC ASSEMBLY

- Eccentric Shaft
- Eccentric Bushing
- Piston
- Adjusting Piston Bushing



Excel Premium Components

GP Series® Cone Crushers

G8™ | G11™ | G12™ | G15™ | GP100™ | GP200™ | GP300™ | GP500™ | GP550™



Excel Bronze Bushings... Simply the Best!

Fit, Form, and Function - that's what we guarantee in every replacement part we deliver. Our Quality Assurance Department scrutinizes every dimension with exacting tolerances to be sure your bushing is perfect in every way, giving your operation an unbelievable value. Less expensive than the OEM, with the highest quality in the business...sounds too good to be true, doesn't it?

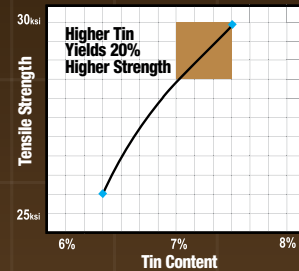

Higher Tensile Strength

Metallurgical Consistency Yields High-Strength Components

In order to maximize tensile strength, Excel certifies our crusher bronze to the top end of the CDA specification for tin. Tougher bushings mean less down-time and fewer replacement cycles. Tin is the most expensive ingredient in the metallurgy of crusher bronze alloys.

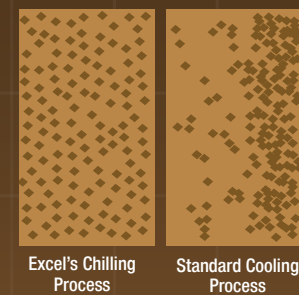

Uniform Lead Dispersion

Unique Chilling Process Stops Migration

Our foundry utilizes a unique chilling process that assures even dispersion of lead throughout the casting. Standard foundry molding techniques allow uneven, non-directional cooling that can cause lead migration. Even dispersion of lead provides consistent lubricity and heat dissipation which increase bushing life and reduce unexpected failures.



Optimum Concentricity

Simultaneous "4-Axis" Turning Ensures Concentricity

Extensive investment in our equipment, our people, and our process gives Excel many unique capabilities, including a special "pinch turning" method in the machining of our crusher bushings which simultaneously cuts the OD and ID. Using this technology guarantees absolute concentricity.

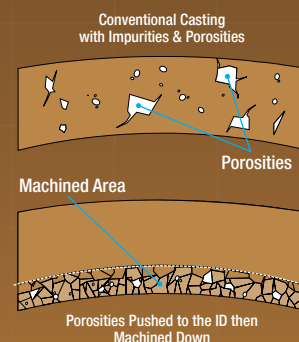

Porosity-Free/ Uniform Grain Structure

Centrifugal Casting Technique Ensures Alloy Integrity

The purity of our raw materials, coupled with controlled, directional solidification during the casting process creates a tighter, denser grain structure in our alloys while eliminating 99.9% of the gas pockets that produce porosity. The integrity of Excel's grain structure ensure strong, long lasting replacement parts.

Excel Gears and Pinions

Excel Uses the Latest Technology

From straight bevel teeth to spiral bevel teeth, Excel offers direct replacement gearing that exceeds OEM quality, starting with the highest quality steel forgings. Our gear "gasher" mill at the beginning of the process and the gear checking center at the end of the process help ensure that Excel delivers high quality gears and pinions efficiently and consistently.

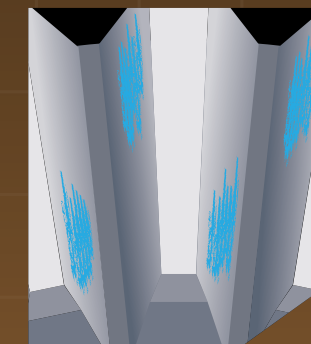
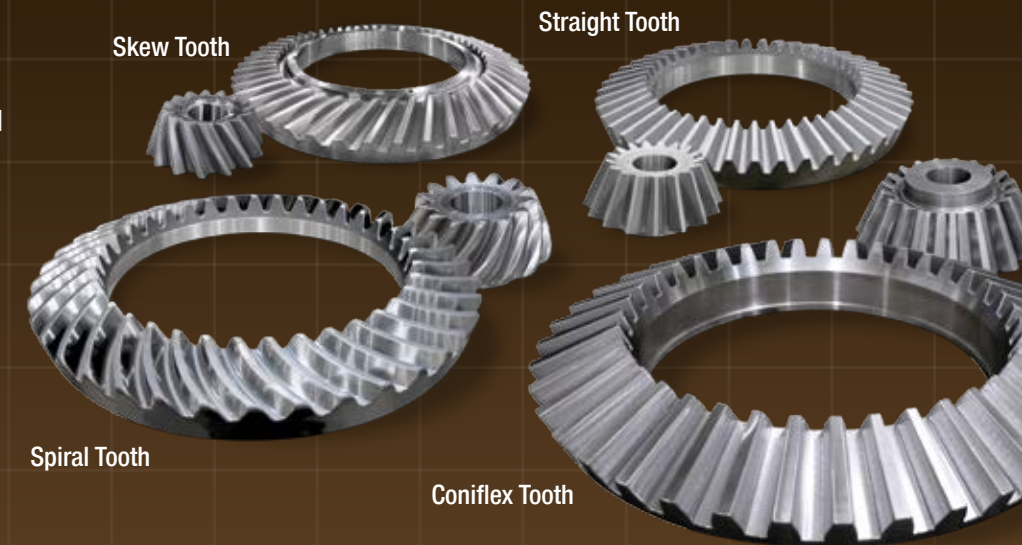

Incorrect Contact

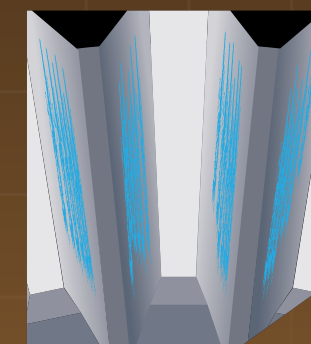

Correct Contact

It's All About the Contact Pattern

The contact pattern is the single most important factor to control when manufacturing crusher gears. Without good tooth-to-tooth contact, the load transfer can point-load the tooth face and result in premature or uneven wear or tooth breakage. Poor contact also creates excessive noise. The load must be distributed properly on the tooth face, and Excel rigorously assures this condition is met through contact-testing with our master gears.



Master Gears and Bluing Process

We ensure field performance and wear life when it comes to gear manufacturing by retaining a high quality set of "master gears" to be used in the production process. Each gear or pinion made is contact-tested against the master and must meet the precise specifications of the gear's contact criteria. Simply put, the benefit to our customer is consistency.



Dedicated to Outstanding Customer Support

+1.309.347.6155

Toll Free 800.523.9129

sales@ExcelFoundry.com

1 Excel Way | Pekin, Illinois | USA

ExcelFoundry.com



For emergency after-hours support, call +1.309.202.8300 to speak to an Excel Professional at any time.



GP® is a mark of Metso® Minerals Industries, Inc. or its affiliates. Excel Foundry & Machine is not an authorized repair facility nor does it have an affiliation with Metso. These terms are used for identification purposes only and are not intended to indicate affiliation with or approval by Metso of Excel. All parts are manufactured by, for and warranted by Excel Foundry & Machine and are not manufactured by, purchased from or warranted by the original equipment manufacturer.

©2017 FLSmidth A/S. All rights reserved.

EXPRI132 - REV2

