

KREBS® Products for the COAL INDUSTRY

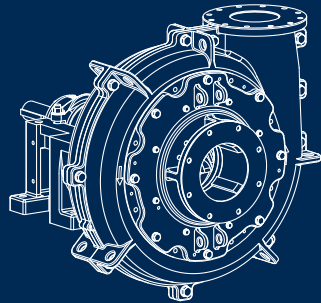

FLS



PUMPS

| | |
|-----------|---|
| millMAX | 4 |
| millMAX-e | 5 |
| slurryMAX | 6 |
| gravelMAX | 8 |

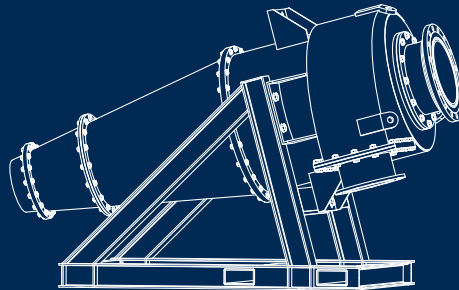

| | |
|---------------------------|----|
| Heavy media cyclones | 9 |
| Ceramic tiles | 11 |
| Coal classifying cyclones | 12 |
| Water-Only cyclones | 14 |
| DeSlime cyclones | 16 |
| Ceramic liners | 17 |

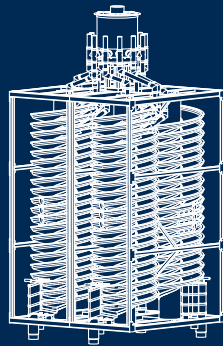

SPIRALS

| | |
|--------------|----|
| Coal spirals | 19 |
|--------------|----|

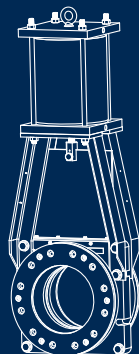

VALVES

| | |
|-------------------|----|
| Knife gate valves | 22 |
|-------------------|----|

KREBS® products for the coal processing industry

KREBS® products are the global leader for high efficiency coal preparation equipment.

We have helped advance the productivity of coal processing operations and provided innovations for greater production, efficiency and reliability. We continue to improve our designs and materials to provide long-lasting urethane and ceramic components.

KREBS® hydrocyclones

Our hydrocyclones provide you with the separation performance you need using leading technology.

KREBS® pumps

Our pumps provide increased wear life with on-line wear adjustment along with higher efficiencies resulting in power and cost savings.

KREBS® coal spirals

Our coal spirals advanced design provide high capacity with recessed cutter position and enhanced separation, reducing product misplacement.

KREBS® knife gate valves

Our knife gate valves provide reliable, long wear life and a 100% bubble tight seal for fine coal slurries.



millMAX™ Original suction side sealing pump

Our millMAX pump has a unique proprietary design developed specifically for severe duty applications



Our horizontal millMAX pumps feature a patented on-line wear clearance adjustment to minimize wear.

The reduction of solids recirculation minimises size degradation and wear. millMAX pumps maintain constant flow and discharge pressure, without increasing speed and/or the chance of motor overload.

Our reverse taper roller bearings increase effective load span to improve B10 life. Typical bearing failure may be due to over greasing but the pumping action of taper rollers discharges grease to the outside, preventing ingress of slurry or over greasing of bearing cartridge.

millMAX™ size range

| U.S. units (in) | Metric units (mm) |
|-----------------|-------------------|
| 3 x 2 | 80 |
| 4 x 3 | 100 |
| 6 x 4 | 150 |
| 8 x 6 | 200 |
| 10 x 8 | 250 |
| 12 x 10 | 300 |
| 14 x 12 | 350 |
| 16 x 14 | 400 |
| 18 x 16 | 450 |
| 20 x 18 | 500 |
| 24 x 20 | 600 |
| 28 x 26 | 700 |

Benefits

- Increased service life
- Reduce power consumption
- More consistent hydrocyclone performance
- Extended bearing life

Applications

- Heavy media feed
- Dilute media
- Classifying cyclone feed
- Thickener underflow/ slurry line

millMAX-e™ Revolutionizing slurry pumping efficiency

We have optimized the millMAX design to bring increased life and higher efficiency to coal processing applications with our millMAX-e slurry pump



The millMAX-e pump is the most efficient slurry pump in its class. It saves power and saves money; thus, minimizing total cost of ownership. The extremely efficient design often allows for smaller motors to be used.

The millMAX-e power frames utilize the same bearing and shaft components as the equivalent millMAX power frames to handle applications with high speed and power requirements.

Required Flow rate for a water flush seal at 10 psig (69 kPa) above pump discharge pressure

| Power frame | High flow (gpm) | High flow (m ³ /h) | Low Flow (gpm) | Low Flow (m ³ /h) |
|-------------|-----------------|-------------------------------|----------------|------------------------------|
| EMAAA | 2.5 | 0.57 | 0.5 | 0.11 |
| MMAA | 8 | 1.82 | 1 | 0.23 |
| MMA | 15 | 3.41 | 2 | 0.45 |
| MMB | 20 | 4.54 | 3 | 0.68 |
| MMC | 25 | 5.68 | 4 | 0.91 |

millMAX-e™ size range

| U.S. units (in) | Metric units (mm) |
|-----------------|-------------------|
| 2 x 1.5 | 50 |
| 3 x 2 | 80 |
| 4 x 3 | 100 |
| 6 x 4 | 150 |
| 8 x 6 | 200 |
| 10 x 8 | 250 |
| 12 x 10 | 300 |
| 14 x 12 | 350 |
| 16 x 14 | 400 |

Benefits

- Decreased total weight of the wet end reducing capital cost
- Regional / Service Centers / Parts Stocking

High efficiency impeller

- Increased efficiencies
- Increased service life
- Increased head

Applications

- Clarified water
- Dilute media
- Classifying cyclone feed

slurryMAX™

Heavy duty split case design

You asked for a split-case pump with longer wear life and better efficiency, which can easily and safely be maintained throughout your plants. That's why we designed our newest KREBS offering - the slurryMAX



Our heavy-duty, split-case-design pump features the latest centrifugal seal technology and the proven KREBS adjustable wear ring technology to provide unsurpassed suction side sealing and slurry efficiency.

The slurryMAX is maintenance friendly and safe with an integrated back liner that bolts securely to the outer drive side casing for ease of assembly and hands-free safety.

Sizes 8x6 and larger feature a removable suction liner assembly for inspection of internals and replacement of impeller without removing the discharge pipe. Easy-to-use lifting jigs allow for safe and rapid rebuilds.

slurryMAX™ size range

| U.S. units (in) | Metric units (mm) |
|-----------------|-------------------|
| 3 x 2 | 80 |
| 4 x 3 | 100 |
| 6 x 4 | 150 |
| 8 x 6 | 200 |
| 10 x 8 | 250 |
| 12 x 10 | 300 |

Benefits

- Even and predictable wear life
- Significant energy savings
- Constant hydraulic performance
- Highly effective centrifugal seal
- Eliminate gland water requirements

Applications

- Heavy media feed
- Dilute media
- Classifying cyclone feed
- Thickener Underflow/ Slurry line

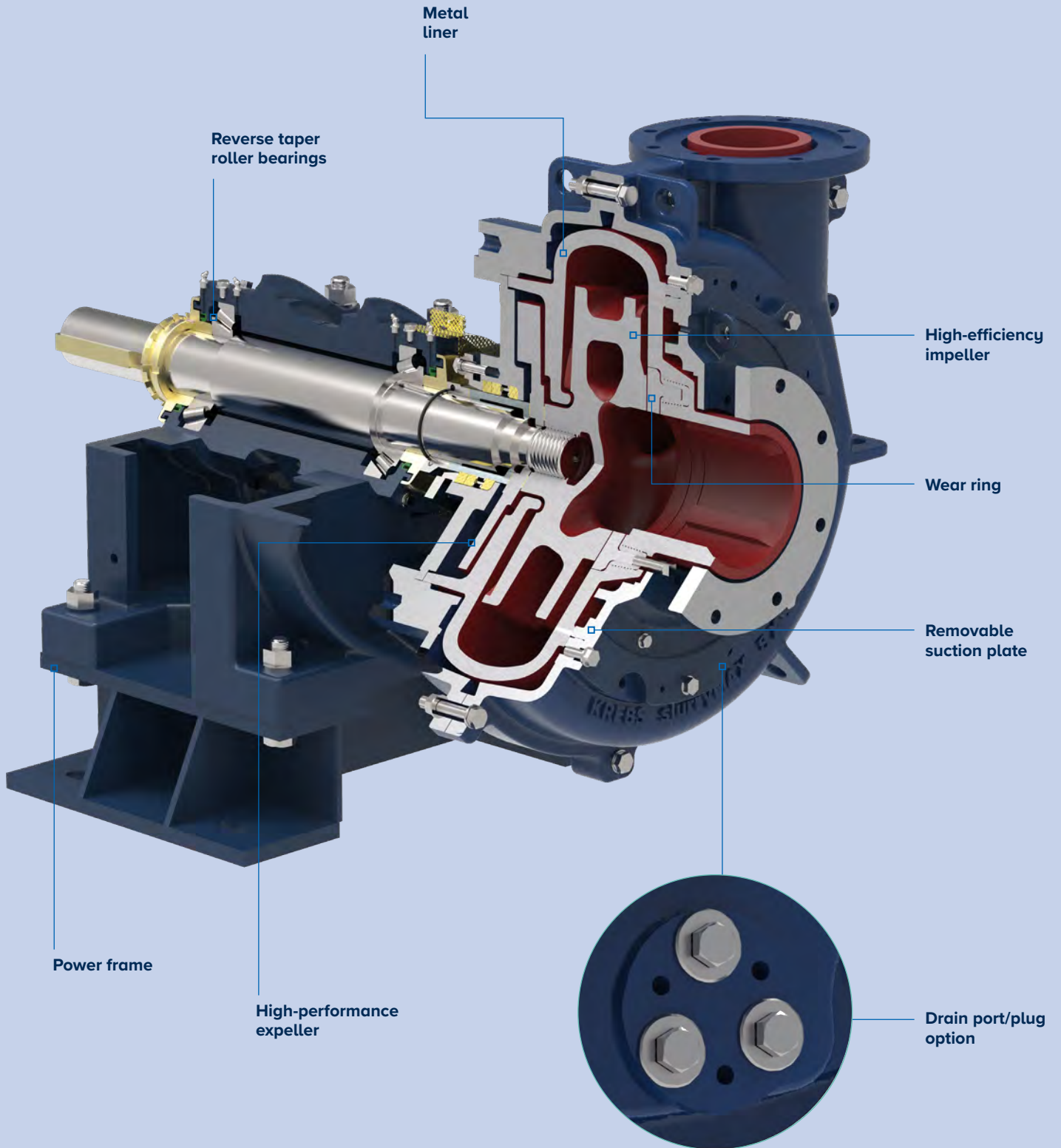

gravelMAX™

Large-solids slurry pump

Our innovative hydraulic design makes the gravelMAX the perfect solution for optimized passing size, efficiency and wear life

The gravelMAX pump treats the cause of pump wear and loss of efficiency by virtue of improved hydraulic design and not with high-price materials of construction. The unique design features a wider, larger diameter impeller and a large cutwater clearance that increases the maximum passing size between the impeller and the suction liner.

The outcome is solids are not being ground in the pump as they would be in conventional designs. The results speak for themselves with fewer wear part change-outs, increased throughput and lower power consumption.

Like other millMAX pump designs, the gravelMAX pump features a patented on-line clearance adjustment.

gravelMAX™ size range

| U.S. units (in) | Metric units (mm) |
|-----------------|-------------------|
| 6 x 4 | 150 |
| 8 x 6 | 200 |
| 10 x 8 | 250 |
| 12 x 10 | 300 |
| 14 x 12 | 350 |



Benefits

- Pump large and abrasive solids
- Maintain cyclone pressure longer
- Reduce the cost per ton
- Adjust pump while running
- Longer service life
- More robust wet-end components

Applications

- Heavy media cyclone feed
- Pond dredging

Heavy Media Cyclone

High efficiency cleaning

Optimize clean coal production with KREBS Heavy Media Cyclones.
Premium ceramics provide longer life cycles without compromising performance

Heavy media cyclones are used in the coal industry and are extremely efficient coal cleaning device using finely ground (-325 mesh / 44 microns) magnetite and water as the “media”.

Within the cyclone, the media creates a buoyancy effect for gravimetric separation and it forces the lighter solids to the centre of the cyclone, where they are transported upward and through the vortex finder. The dense mineral matter spirals downward and out through the apex.

Because heavy-media cyclones are usually operated in a near-horizontal orientation, they allow for large apex sizes to assist in refuse removal.

Media circulating density primarily determines separation gravity. We recommend keeping pressure relatively low to reduce magnetite classification.

One of the most important benefits of our heavy-media cyclone is its high efficiency, stemming from a number of design features our expertise in the field.



Benefits

- High-efficiency cleaning of coarse material at higher feed rates
- Long wear life provided by ceramic lining in abrasive applications

Acceleration Wedges

Cyclones 26-in (660 mm) diameter and larger utilise a proprietary ceramic “acceleration wedge” to modify capacity and G-forces.

- Smaller wedges for higher capacity
- Larger wedges allow for higher G-forces

Performance

Our heavy-media cyclones can handle top-size feed particles ranging up to 4-in (102 mm), and have capacities of 85 stph (77 mtph) to 985 stph (895 mtph) per cyclone.

Premium ceramics in the apex promote continuous separation efficiency throughout the life of the cyclone

Typical operation parameters for Heavy Media Cyclones

U.S. UNITS

| Model designation | Feed particle maximum size (in) | Dry feed capacity* (stph) | Pulp flowrate range (gpm) | Head equivalent (ft) |
|-------------------|---------------------------------|---------------------------|---------------------------|----------------------|
| D20LSB | 3/4 | 85 | 1,050 | 15 |
| D26B | 1 1/2 | 150 | 1,910 | 20 |
| CoalMAX26 | 1 1/2 | 160 | 2,045 | 20 |
| D263B | 1 1/2 | 165 | 2,065 | 20 |
| D30B | 2 | 225 | 2,830 | 23 |
| D33T154 | 2 1/2 | 290 | 3,650 | 25 |
| D33T214 | 2 1/2 | 315 | 3,930 | 25 |
| D40B | 3 | 460 | 5,760 | 30 |
| D44B-A | 3 | 475 | 5,940 | 33 |
| D44B-U | 3 | 580 | 7,280 | 33 |
| D48B | 3 1/2 | 725 | 9,100 | 36 |
| D55B | 4 | 985 | 12,300 | 41 |

METRIC UNITS

| Model designation | Feed particle maximum size (mm) | Dry feed capacity* (mtph) | Pulp flowrate range (m ³ /h) | Head equivalent (m) |
|-------------------|---------------------------------|---------------------------|---|---------------------|
| D20LSB | 19 | 77 | 238 | 4.6 |
| D26B | 38 | 136 | 434 | 6.1 |
| CoalMAX26 | 38 | 145 | 464 | 6.1 |
| D263B | 38 | 150 | 469 | 6.0 |
| D30B | 51 | 205 | 643 | 7.0 |
| D33T154 | 63 | 264 | 829 | 7.6 |
| D33T214 | 63 | 286 | 892 | 7.6 |
| D40B | 76 | 418 | 1,308 | 9.2 |
| D44B-A | 76 | 432 | 1,348 | 10.1 |
| D44B-U | 76 | 527 | 1,653 | 10.1 |
| D48B | 89 | 659 | 2,066 | 11.0 |
| D55B | 102 | 895 | 2,792 | 12.6 |

* Based on a 4:1 media-to-coal ratio

* These capacities represent maximums for units fitted with the largest inlet and vortex finder

Pre-engineered tile lining

Our ceramic tiles are machined in the green state and then fired to become an interlocking, serialized component

Extra thick ceramic tile lining is in high wear areas is critical in our heavy-media cyclones, as dense mineral matter can be very abrasive.

During their manufacture, we machine each ceramic tile in its “green” state, and then fire them to become interlocking, serialised liner components. Although this process is relatively expensive, the resulting increase in wear life pays for itself, and is one more reason why operations choose our heavy-media cyclones over other models that utilise flat tile.

We offer our pre-engineered tiles in two different grades, with 1-in to 1.5-in (25 to 38 mm) thickness, to optimise wear life.

After assembly of tile lined sections, all cyclones are thoroughly inspected before painting.



Final inspection of ceramic tiles and grout before shipping to customer.

gMAX[®]

Coal Classifying Cyclone

KREBS gMAX Coal Classifying Cyclones have been engineered specifically for coal classification to maximize fine coal recovery and reduce maintenance intervals

The innovative gMAX inlet has replaced the former KREBS involute feed inlet design – improving upon what had long been considered the preeminent, state-of-the-art design for more than 40 years.

The outer wall involute design entrance pre-classifies the feed solids prior to entering the main body of the cyclone. The inlet head of the gMAX also includes an improved vortex finder design.

These improvements result in reduced misplacement of coarse coal to the over-flow and dramatically increased wear life. By using premium ceramics in the lower section of the cyclone, we've boosted overall wear life, greatly increasing the intervals between complete cyclone rebuilds.

The KREBS gMAX coal classifying cyclone has equivalent capacity as its larger diameter counterpart, resulting in a finer separation within the same footprint. The gMAX coal classifying cyclones are designed with urethane encased ceramic to prevent external corrosion within preparation plants.

- Available in sizes ranging from 6-in to 20-in diameter with full polyurethane encasement
- Available with cone angles of 10.5 or 20 degrees.



gMAX hydrocyclones are available in sizes ranging 6" to 20" diameter

Benefits

- Minimized coarse solids misplacement to overflow
- Longer liner wear life
- Requires fewer cyclones for optimal performance
- Operates at higher feed rates, achieving the same separation size

Performance

- gMAX classifying cyclones can handle 1/2" (13mm) top-size
- Capacities up to 50 STPH (45MTPH) per cyclone
- Feed Density up to 15% solids; underflow density of 40-50% solids are normal for raw coal applications
- Finer D95 cutpoint for coal classification at higher feed rate

Typical operating parameters for Coal Classifying Cyclones

U.S. UNITS

| Model designation | Feed particle maximum size (in) | Effective mesh of separation (mesh) | Dry feed range** (stph) | Pulp flowrate range* (gpm) | Pressure drop range (psi) | Maximum feed percent solids (WT%) (VOL%) | |
|-------------------|---------------------------------|-------------------------------------|-------------------------|----------------------------|---------------------------|--|------|
| gMAX6BU | 28 Mesh | 200/270 | 3-6 | 95-230 | 25-30 | 5% | 3.5% |
| gMAX10-10 | 1/8 | 150/200 | 7-12 | 275-455 | 15-25 | 7% | 4.5% |
| gMAX12LB-10 | 1/4 | 100/150 | 12-19 | 475-750 | 15-25 | 10% | 7% |
| gMAX15LB-20 | 1/2 | 100/150 | 17-28 | 650-1060 | 15-25 | 12% | 8% |
| gMAX15LB-10 | 1/2 | 100/150 | 20-31 | 785-1200 | 15-25 | 13% | 8% |
| gMAX20LB-10 | 1/2 | 65/100 | 30-49 | 1155-1900 | 15-20 | 15% | 11% |

METRIC UNITS

| Model designation | Feed particle maximum size (mm) | Effective mesh of separation (mesh) | Dry feed range** (mtph) | Pulp flowrate range* (m ³ /h) | Pressure drop range (kPa) | Maximum feed percent solids (WT%) (VOL%) | |
|-------------------|---------------------------------|-------------------------------------|-------------------------|--|---------------------------|--|------|
| gMAX6BU | 0.6 | 200/270 | 3-5 | 22-52 | 138-207 | 5% | 3.5% |
| gMAX10-10 | 3 | 150/200 | 6-11 | 62-103 | 103-172 | 7% | 4.5% |
| gMAX12LB-10 | 6 | 100/150 | 11-17 | 108-170 | 103-172 | 10% | 7% |
| gMAX15LB-20 | 13 | 100/150 | 15-25 | 148-241 | 103-172 | 12% | 8% |
| gMAX15LB-10 | 13 | 100/150 | 18-28 | 178-273 | 103-172 | 13% | 8% |
| gMAX20LB-10 | 13 | 65/100 | 27-45 | 262-432 | 103-138 | 15% | 11% |

* Maximum flowrate based on units fitted with the largest inlet and vortex finder

**Based on 10% feed solids by weight / and dry s.g. of 1.6



Water-Only Cyclone

Our water-only cyclone offers a high volume and small footprint water based density separator. This paired with the KREBS Spirals or FLS Reflux Classifiers offer an alternate approach to fine coal cleaning



Water-only cyclones are used to “clean” or “wash” raw coal, making a density separation. The cyclone design relies on the fact that mineral matter is denser than coal. In this case, a truncated cone bottom allows a hindered-settling bed to form, which rejects lighter coal particles. At the same time, an elongated vortex finder lifts the light coal particles to the overflow.

A characteristic of the design is the possibility of some coal losses through the apex due to classification of larger coal particles. This effect can be eliminated by using two-stage circuitry, where the “lost” coal particles are re-cleaned in coal spirals, reflux classifiers, or secondary water-only cyclones. The result is a more efficient system separation.

Finer coals must be cleaned in smaller-diameter water-only cyclones; otherwise, drag forces in large-diameter cyclones cause the fine, high-ash particles to report to clean coal. Both pressure and feed density affect the separating gravity.

Our D15LB-S-327 is specifically designed to clean 1MM top size coal. Combined with a second stage spiral circuit, the system can provide efficient separation densities from 1.65 to 2.00 SG.

Benefits

- Shorter vortex finders ensure low separating densities
- Long body ensures low separating densities
- Many different liner materials are available
- Simulations and technical support available

Performance

- Designed to produce a low ash coal product
- Able to handle feed particle 3/4” top-size
- Separating density adjustable with pressure, apex size and vortex finder length

Typical operation parameters for Water Only Cyclones

| Model designation | Feed particle maximum size (in) | Effective mesh of separation (mesh) | Dry feed range** (stph) | Pulp flowrate range* (gpm) | Pressure drop range (psi) | Maximum feed percent solids (WT%) (VOL%) | |
|-------------------|---------------------------------|-------------------------------------|-------------------------|----------------------------|---------------------------|--|-----|
| D10LB-S218 | 28 Mesh | 100/150 | 4-8 | 190-260 | 8-15 | 10% | 7% |
| D15LB-S245 | 14 Mesh | 65/100 | 12-18 | 400-580 | 10-18 | 12% | 8% |
| D15LB-S327 | 10 Mesh | 65/100 | 12-25 | 510-720 | 10-20 | 12% | 8% |
| D20B-S260 | 1/4-in | 48/65 | 25-45 | 820-1050 | 12-20 | 15% | 11% |
| D20LSB-S333 | 1/2-in | 35/48 | 35-60 | 1100-1500 | 12-20 | 15% | 11% |
| D26-S224 | 3/4-in | 35/48 | 50-90 | 1490-2200 | 12-22 | 20% | 15% |

METRIC UNITS

| Model designation | Feed particle maximum size (mm) | Effective mesh of separation (mesh) | Dry feed range** (mtph) | Pulp flowrate range* (m ³ /h) | Pressure drop range (kPa) | Maximum feed percent solids (WT%) (VOL%) | |
|-------------------|---------------------------------|-------------------------------------|-------------------------|--|---------------------------|--|-----|
| D10LB-S218 | 0.6 | 100/150 | 4-7 | 43-59 | 55-103 | 10% | 7% |
| D15LB-S245 | 1.2 | 65/100 | 11-16 | 91-132 | 69-124 | 12% | 8% |
| D15LB-S327 | 1.7 | 65/100 | 11-23 | 116-164 | 69-138 | 12% | 8% |
| D20B-S260 | 6 | 48/65 | 23-41 | 186-238 | 83-138 | 15% | 11% |
| D20LSB-S333 | 13 | 35/48 | 32-54 | 250-341 | 83-138 | 15% | 11% |
| D26-S224 | 19 | 35/48 | 45-82 | 338-500 | 83-152 | 20% | 15% |

De-slime Cyclone for finer separation

Our 6-in gMAX cyclone is ideal for ultra-fine coal desliming applications requiring 270-325 mesh separations. More recovery to product allows for maximizing the resource potential

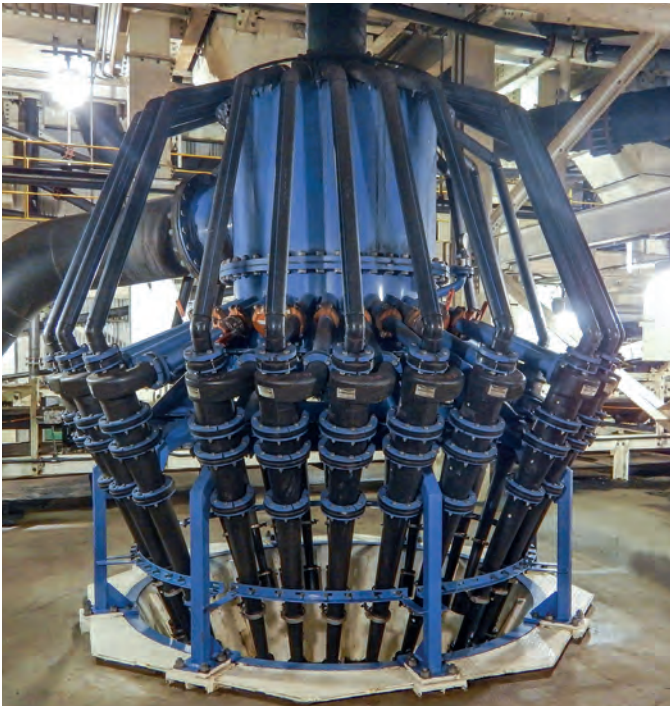

Used prior to flotation circuits, the deslime cyclone removes ultrafine clays and other inert material from the primary classifying cyclone overflow stream.

Desliming reduces overall volume to flotation, increases flotation residence time, and can reduce downstream equipment required.

KREBS gMAX desliming cyclone designed for optimum fine coal recovery to underflow.

Manifold designs include custom “spider” and conventional radial manifolds.

- Maximum strength and wear characteristics
- Design allows for rapid inspection and replacement
- Minimal footprint with maximum throughput
- Molded urethane cyclone design provides corrosion resistance
- Quick disconnect lower cone and apex assemblies
- Proven ultra-fine coal separation utilizing our gMAX technology in a desliming application
- Optimize overall circuit efficiency

Ceramic liners for cyclones

Premium ceramic liners maintain original cyclone geometry for more operating hours allowing operators to optimize performance

Ceramic liner options

Most coal applications require all wetted cyclone surfaces to be ceramic lined especially Heavy Media Cyclones where dense magnetite and raw coal (containing sand and rocks) impinges upon the liners.

For severe applications, we may recommend that upper portions of the cyclone be protected with nitride bonded silicon carbide (CR) liners, while the lower sections and apex be protected with more abrasive resistant ceramic liners. In extremely severe applications a reaction bonded silicon carbide (CX) apex insert might be recommended. With several ceramic liner options, maintenance is markedly reduced.

High quality cast ceramics provide geometric accuracy equal to high-chrome cast iron but provide significantly longer service life. Using only cast liners results in less turbulence, finer cut points and longer service life.

KREBS flexible design permits applying special ceramics where required throughout the cyclone body.

Ceramic liner inspection

With several ceramic liner options available, maintenance can be markedly reduced. For classifying, water-only, and heavy media cyclones, apex wear is the most important issue and the easiest to monitor. With all pump motor switches properly secured, a light and measuring device are usually the only items required for this inspection.

To inspect the other liners, usually an apex assembly or overflow pipe/vortex finder can be removed. If this still doesn't allow adequate view of all liners, additional disassembly will be required. Because the liners are somewhat brittle, all ceramic lined cyclones should be handled carefully; hammering on any surface of the cyclone is not recommended.

Because KREBS ceramic lined cyclones lasts so long, some maintenance expertise may be lost between rebuilds. In this case, please contact your local representative for assistance; some of the representatives may also be able to provide a rebuild or exchange service.



Typical ceramic liners for cyclones

| Model designation | CC | CB | CR | CX | CZ |
|-------------------------------------|----|----|----|----|----|
| Heavy Media Cyclone Inlet | ● | ● | – | – | – |
| Heavy Media Cyclone Lower Cone | ● | ● | ● | ● | ● |
| Heavy Media Cyclone Apex | ● | ● | ● | ● | ● |
| gMAX Classifying Cyclone Inlet | – | – | ● | ● | – |
| gMAX Classifying Cyclone Lower Cone | ● | ● | ● | ● | ● |
| gMAX Classifying Cyclone Apex | ● | ● | ● | ● | – |
| Water Only Cyclone Inlet | – | – | ● | ● | – |
| Water Only Cyclone Truncated Cone | ● | ● | ● | ● | – |
| Water Only Cyclone Apex | ● | ● | ● | ● | ● |

● Standard liner (standard varies by cyclone diameter) ● Available liner – Not available

CERAMIC MATERIALS

| CC | CB | CR | CX | CZ |
|---|--|--|--|---|
| Alumina bonded silicon carbide | Alumina bonded silicon carbide | Nitride bonded silicon carbide | Reaction bonded silicon carbide | Alpha sintered silicon carbide |
| 90% Alumina Tile, this material holds up well in coal applications and is used to line cones and some apexes. | 96% Alumina Tile, this material holds up well in coal applications and is used to line the difficult geometry associated with the inlet head of large diameter heavy media cyclones. | This has been the standard material used by KREBS for inlet heads and cylinders and cones for over 30 years. This material has been modified over the years to improve the dimensional consistency of the parts, but the basic composition has remained unchanged. | This is typically used in highly abrasive applications. It will outlast the standard CR material by about 3 times. | This is typically used in most extreme abrasive applications. It is the most wear resistant ceramic material we offer and it will outlast the standard CR material by 9-10 times. |

Coal Spirals

Coal spiral concentrators are designed to effectively clean 1 mm x 0.15 mm material. Spirals offer low maintenance and consistent performance at high capacity

The KREBS coal spiral is a technologically advanced design with rougher/cleaner CPX™ spiral that allows coal to be rewashed in a second stage spiral helix located immediately below the primary spiral.

Spiral concentrators use differences in density to separate fine coal simply, efficiently, and cost effectively

FLS offers a comprehensive range of spiral units for coal preparation available in single, double, and triple start configurations with single pass or rougher/cleaner designs available.

KREBS coal spirals are supplied in complete modular designs including support framework, feed distribution system and product piping system. Assemblies will be designed to meet your application requirements.

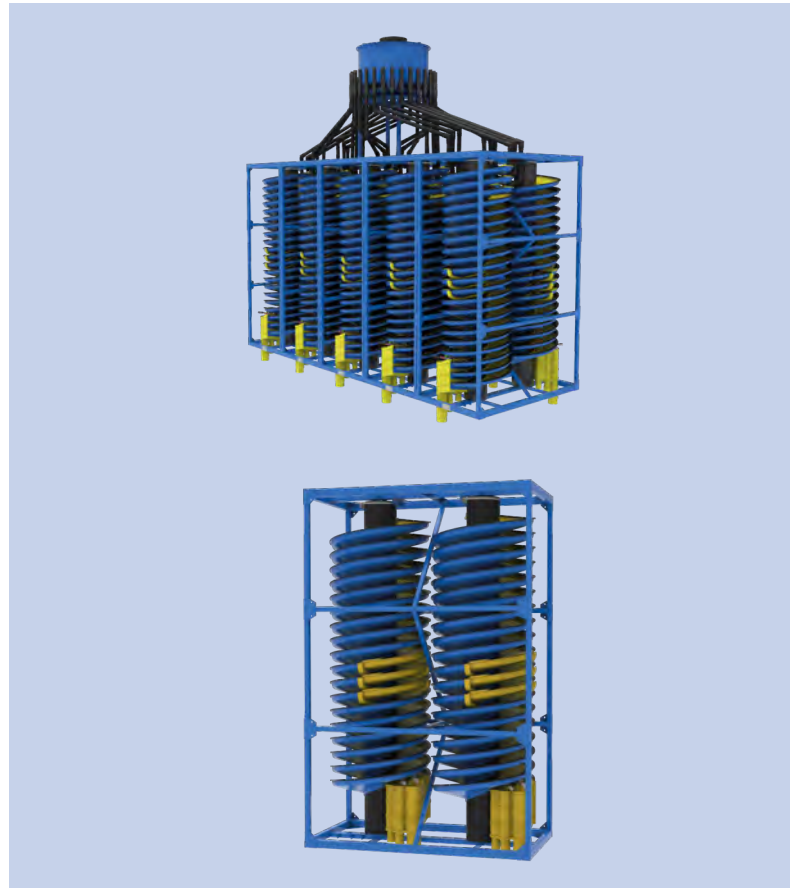

Benefits

- Integral product piping system which eliminates the need for open launders
- Wear and corrosion resistant construction
- New product boot design with vortex breaker for a longer wear life
- Integral “lock-in-place” cutter positioner and indicator
- Recessed cutter position for enhanced separation, reducing product misplacement

Performance

- The GPX and CPX Coal Spirals are designed to produce a low ash coal product at high efficiency while rejecting a high ash refuse stream
- Spiral feed capacity is 2-3 STPH (1.8 - 2.7 MTPH) per start dependent on raw coal quality and refuse amount to be discarded
- Optimum spiral feed size is -1 mm to 0.15 mm (14 M x 100 M)

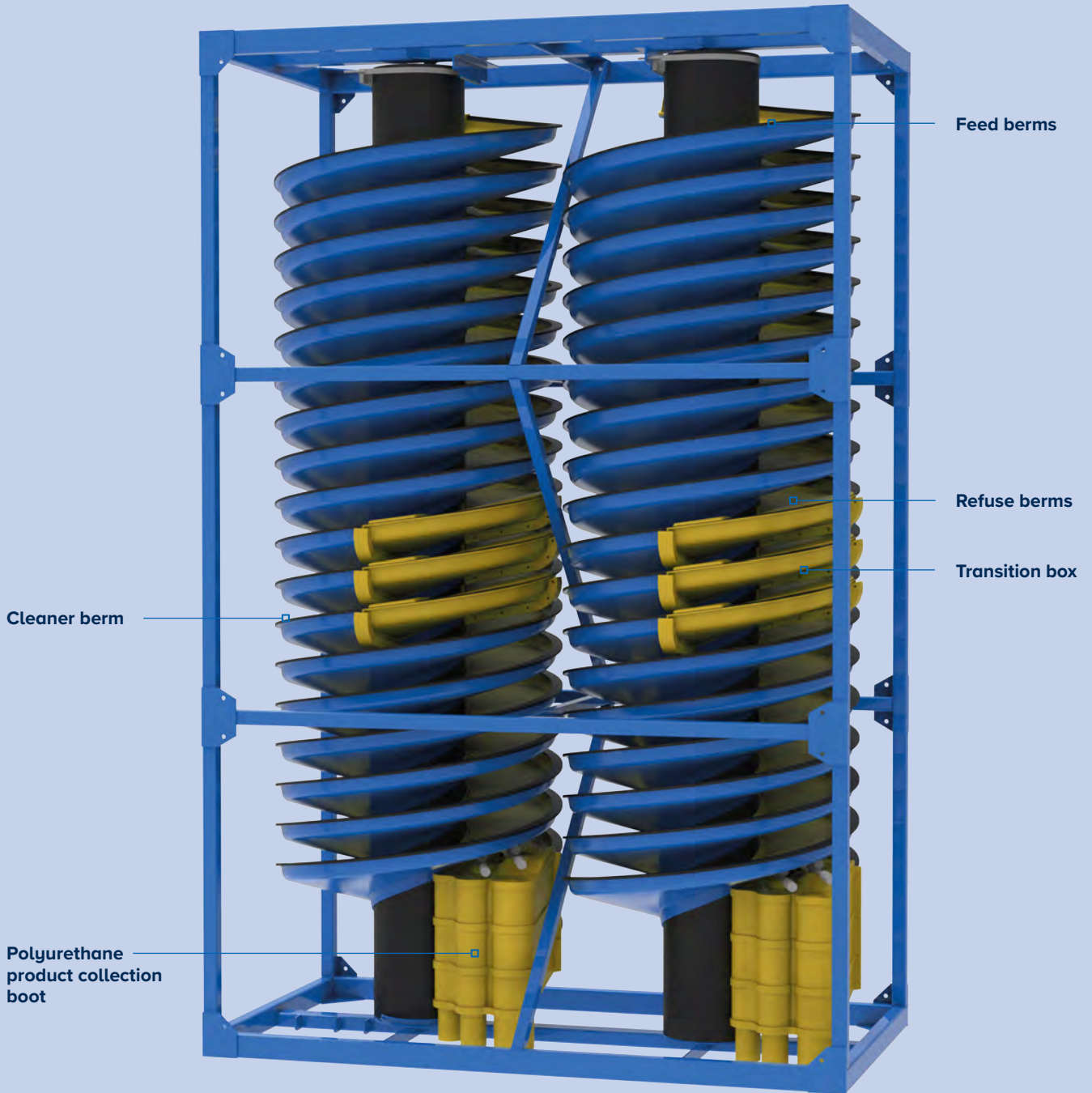

Polyurethane collection boot



- **Collection boot**
- Handles allow for positioning of all cutters simultaneously
- No need to reach into helix to adjust
- Increased capacity
- Mechanism allows positive lockout once selection is made

- **Internal profile**
- Revised internal profile assures no misplacements into other streams
- Internal rotation breaker reduces wear on boot assembly

Capitalize the Polyurethane

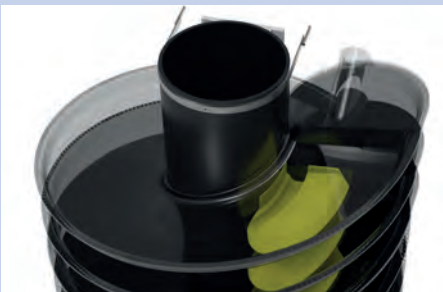

- **Feed berms**
- Allows for low flow conditions without losing coal
- **Refuse berms**
- Used to ensure no coal loss on very high yield coals

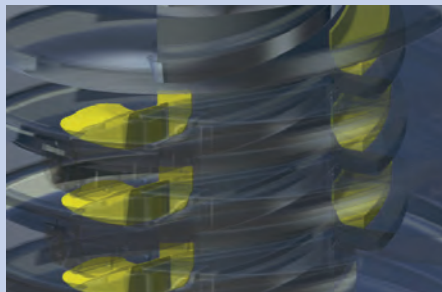

- **Cleaner berm**
- We will select appropriate style based on your plant conditions



- **Transition box**
- Re-mixes coal and mids prior to final turns
- Allows for a better separation
- Refuse is bypassed to assure no product contamination

Technequip™ for fine coal applications

Technequip™ knife gate valve is a heavy duty premium valve, designed for harsh service



Our Technequip™ knife gate valve is a heavy-duty premium valve, designed for harsh service. It provides reliable, long wear life and a 100%-bubble-tight seal for fine coal slurries.

Technequip valves are available with manual handwheel, bevel gear, pneumatic, hydraulic and electric actuators. Numerous accessories and options are available, including, but not limited to, solenoids, limit switches, junction boxes and alternate gate and elastomer materials.



Benefits

- Reliable operation
- Longer wear life
- Open body design ejects material from the bottom to ensure a 100% bubble tight seal
- Replaceable wear sleeves
- Fluorocarbon-coated stainless steel gate

Performance

- Pump suction valves
- Cyclone isolation or distribution



KREBS® PCV Regional Global Sales

FLSmidth Inc.

Tucson Operations
Tucson, AZ USA
Tel + 1 520 744 8200
krebs@flsmidth.com

FLSmidth GmbH Austria

Neusiedl am See, Austria
Tel: +43 2167 3345
krebseurope@flsmidth.com

FLSmidth Pty Ltd.

Welshpool
Western Australia
Tel: +61 8 6258 4800
krebsaustralia@flsmidth.com

FLSmidth - Chile

Santiago, Chile
Tel: +56 2 2463 8350
krebschile@flsmidth.com

FLSmidth - South Africa

Stormill, Randburg
South Africa
Tel: +27 0 10 210 4750
krebsafrica@flsmidth.com

Learn more about our
PCV product offerings

[KREBS® Slurry Pumps](#)

[KREBS® Cyclones](#)

[KREBS® Slurry Valves](#)

[KREBS® Vessels](#)

[KREBS® DeSanders](#)

Follow us here



flsmidth.com/linkedin



flsmidth.com/twitter



flsmidth.com/facebook



flsmidth.com/instagram



flsmidth.com/youtube

Contact us

FLSmidth A/S

2500 Valby
Denmark
Tel. +45 36 18 10 00
info@flsmidth.com

FLSmidth Inc.

Tucson Operations
Tucson, AZ 85743
USA
Tel + 1 520-744-8200
krebs@flsmidth.com



flsmidth.eco/contact

Copyright © 2023 FLSmidth A/S.
All Rights Reserved. FLSmidth and FLS are (registered) trademarks of FLSmidth A/S. This brochure makes no offers, representations or warranties of any kind (express or implied), and information and data contained in this brochure are for general reference only and may change at any time. FLSmidth does not guarantee or make any representation regarding the use or the results of the information or the data provided in the brochure in terms of its correctness, accuracy, reliability or otherwise, and shall not be liable for any loss or damage of any kind incurred as a result of the use of the information or data provided in the brochure.