

## Product datasheet

# Circular Vibrating Screen CK 802 / CK 803 / CK 804

## Advanced screen technology

Our circular vibrating screens are used for screening rock, ore and similar bulk materials, as well as in recycling and waste disposal. The size of the machines is tailored to your requirements and installation conditions. Our screens can handle higher throughput rates and meet demands for accurate separation according to grain size.

### Efficient screening

#### Screen cloths

- Perforated plates, polyurethane panels or woven wire available
- The design permits the use of screen covers made by different manufactures
- Mesh size can be adapted to the requirements of a certain application

### Adjustability

- Modifiable stroke up to 13 mm by unbalanced weights
- Adjustable rotational speed

### Screen tray

- Bolted design without any welding at the side walls ensures maximum fatigue strength

### Vibration isolation

- Mitigation of dynamic loads by steel springs

### Roller bearings

- Special spherical roller bearings for high vibrations

### Drive

- V-belt drive with protection hood

# FLS

# Circular Vibrating Screen CK 802 / CK 803 / CK 804

## Options

- Dedusting hood

## Technical specification

General data	
Materials	Limestone, ore, quartzite, etc.
Maximum feed size	200 mm edge length
Screen	
Type of screen	Circular-motion
Screen area dimensions (a x b):	5,000 mm x 1,650 mm
Screening area (per deck)	8 m <sup>2</sup>
Number of screen decks	2, 3 or 4
Screen covering	Perforated plate, polyurethane or woven wire
Inclination	18°
Number of shafts	2
Vibration isolation	Steel springs
<b>Main dimensions (l x w x h)</b>	– 2 decks: 6,020 mm x 2,320 mm x 1,180 mm – 3 decks: 6,240 mm x 2,320 mm x 1,720 mm – 4 decks: 6,290 mm x 2,320 mm x 1,980 mm
<b>Total weight</b>	– 2 decks: Up to 4.8 mt – 3 decks: Up to 6.0 mt – 4 decks: Up to 7.1 mt
Drive	
Drive concept	V-belt
<b>Motor power</b>	– 2 decks: 2 x 7.5 kW – 3 decks: 2 x 9 kW – 4 decks: 2 x 9 kW

## Working principle

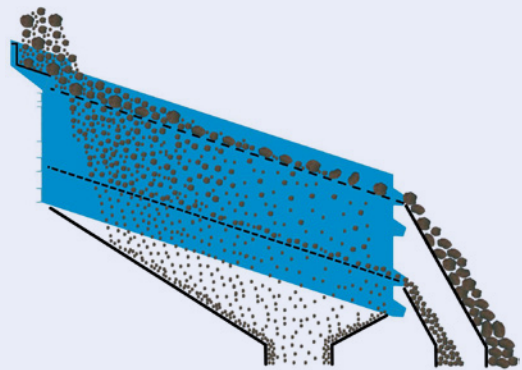

## Main dimensions

Side view

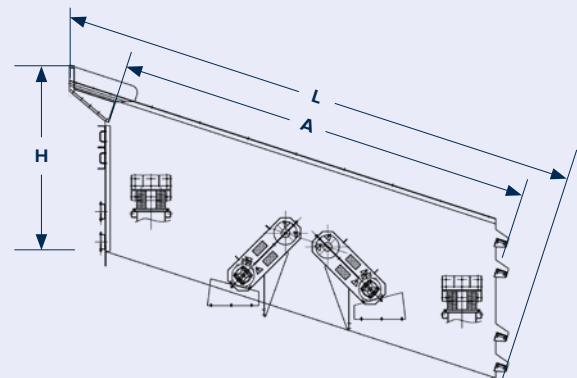

Top view

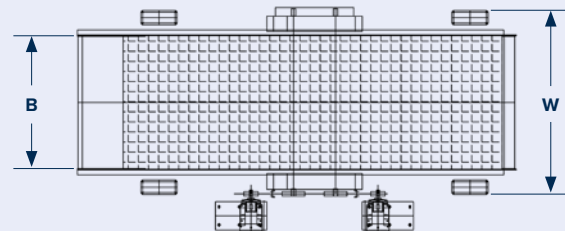

**FLSmidth A/S**  
2500 Valby  
Denmark  
Tel. +45 3618 1000  
info@flsmidth.com

[www.flsmidth.com](http://www.flsmidth.com)

**FLSmidth Inc.**  
Salt Lake City Operations  
Midvale, UT 84047-5559  
USA  
Tel. +1 801 871 7000  
info.sl@flsmidth.com

**FLSmidth Mining Technologies GmbH**  
Ennigerloh Operations  
59320 Ennigerloh  
Germany  
Tel. +49 201 828 3000  
mining-technologies@flsmidth.com

Copyright © 2023 FLSmidth A/S.  
All Rights Reserved. FLSmidth and FLS are (registered) trademarks of FLSmidth A/S. This brochure makes no offers, representations or warranties (express or implied), and information and data contained in this brochure are for general reference only and may change at any time.