



FLSmidth cuts wear maintenance and increases throughput by 7%

Background

The gyratory crusher at a large copper mine was experiencing decreased liner life over time. This forced the site to change their mantle linings much too frequently – nearly every two weeks. Not only did this increase the cost of wear parts, but each change also required 10 hours of downtime. We were contacted to help provide a solution.

Defining the problem

When visiting the site, the FLSmidth team discovered that the crusher feed contained a very high percentage of fines, which intensified wear. The liners would lose the crusher OSS Setting very quickly, and consequently, each concave campaign required an average of five sets of mantles. Site was purchasing their liners from a 3rd party company, who was not able to provide an optimal solution to the ever-increasing cost of maintenance and parts and subsequently reached out to FLSmidth to review their operation.

The team was tasked with providing a solution that would extend mantle life and so reduce the number of times the crusher had to be taken out of service for maintenance.

When a large copper mine faced problems with its gyratory crusher mantle linings, it called on us to help. Our solution significantly improved wear performance and material feed through the crusher. As a result, the mine has experienced a significant drop in maintenance costs, while achieving a 7% increase in crusher throughput. This is a clear win for productivity; it represents important sustainability benefits too.

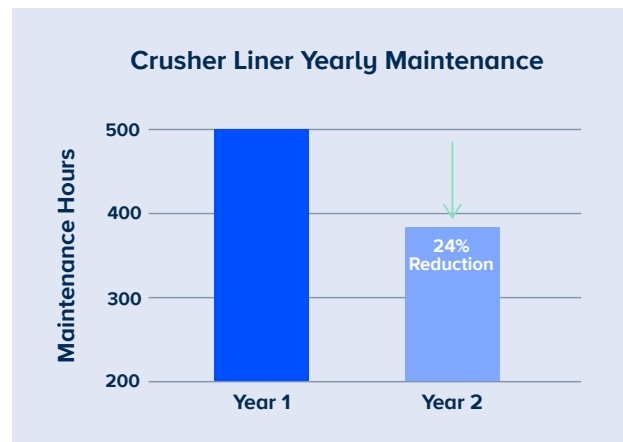

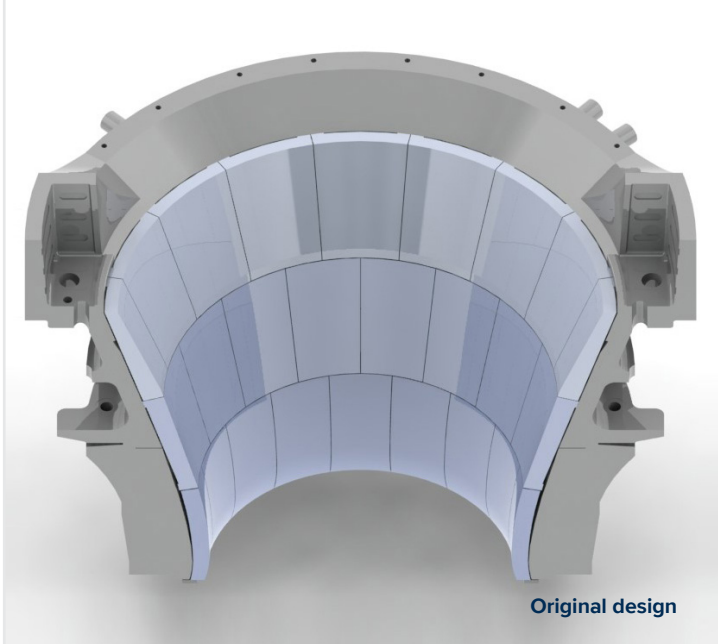

Original design

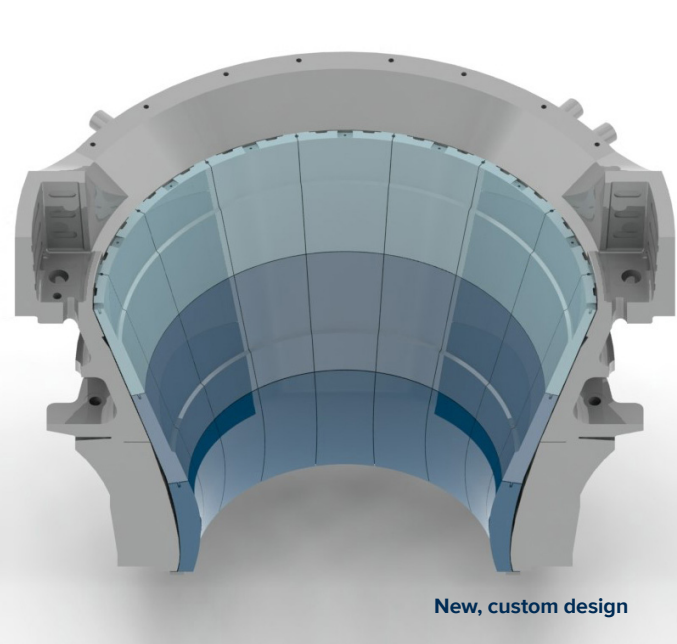

New, custom design

The Solution

Our team determined that the best way to improve the life was to design a custom chamber to accommodate the abrasiveness of the feed and also increase life.

Our solution included the following actions:

- Designing a custom chamber to minimize the loss of crusher OSS as the chamber wears
- Aligning the chemical composition of the mantles and concaves with this high abrasion application.
- Condition monitoring services, including 3D scanning and wear and performance monitoring.

The Results

These changes combined to reduce the number of mantles from five to only two per campaign – with dramatic benefits to mine performance:

- A saving of 24% in yearly maintenance costs. This was achieved by reducing consumption of mantles from twenty to just eight, as well as the associated maintenance costs to facilitate these works.
- Even more dramatically, the new liner profile design facilitated higher production. The site has been reporting an increase in daily tonnage by 7%.

These results are not just a major win for the mine’s bottom line; they also provide significant sustainability benefits, notably by reducing the quantity of worn liners that go to waste. In addition, reducing consumption of wear materials helps to lower the industry’s Scope 3 carbon emissions¹ and is thus another step on the path to zero-emissions mining.

FLSmidth A/S

2500 Valby
Denmark
Tel. +45 36 18 10 00
info@flsmidth.com

FLSmidth Inc

Salt Lake City Operations
Midvale, UT 84047-5559
USA
Tel. +1 801 871 7000
Info.slcc@flsmidth.com

www.flsmidth.com

Copyright © 2023 FLSmidth A/S. All Rights Reserved. FLSmidth is a (registered trademark) of FLSmidth A/S. This brochure makes no offers, representations or warranties (express or implied), and information and data contained in this brochure are for general reference only and may change at any time.

