

Product datasheet

Single-toggle Jaw Crusher EB 11-08

Simply easy crushing

High-capacity, high performance Jaw Crushers for primary crushing. With this crusher, material is crushed by compressive and shear forces. Flywheels with high moments of inertia generate a high crushing energy and compensate crusher peak loads. The main feature of the crusher is the enhanced kinematics of the swing jaw with a high stroke in the feed and discharge area, which ensures very high throughput rates.

Benefits

- Simplified transportation, installation and maintenance thanks to compact design
- Reduced space requirements and no need for local engineering and fitting thanks to integral motor base
- Optimised wear elements enable fast and easy maintenance, reducing service times by up to 20%.
- Optimised geometry of the crushing chamber leads to up to 10% high throughput rates compared to market benchmark
- Efficient utilisation of the crushing chamber results in lower and more uniform wear of the crushing tools leading to up to 10% longer service life of bearing and wear parts

Features

Crushing chamber

- Optimised crushing chamber resulting in reduced wear and long operating life
- Optimum angle of nip for hard and tough materials

Crushing jaws

- Crushing jaws of high-grade manganese-alloyed steel
- Developed crushing plate profiling optimised for all kinds of feed material
- The crushing jaws can freely expand avoiding the transmission of high stresses to other components
- Easy change of the crushing jaws
- Strengthened design of the swing jaw to take up peak loads

Quick change of gap settings

- Hydraulically assisted gap setting

Drive concept

- V-belt drive
- Good accessibility
- Easy maintenance

Monitoring devices

- Proper functioning is monitored by speed and temperature sensors

Housing and base frame

- Reinforced front- and back walls
- Cheek plates made of high-strength special steel

Optional automatic grease lubrication unit

- Lubrication for bearings and labyrinths
- Lubrication system is monitored

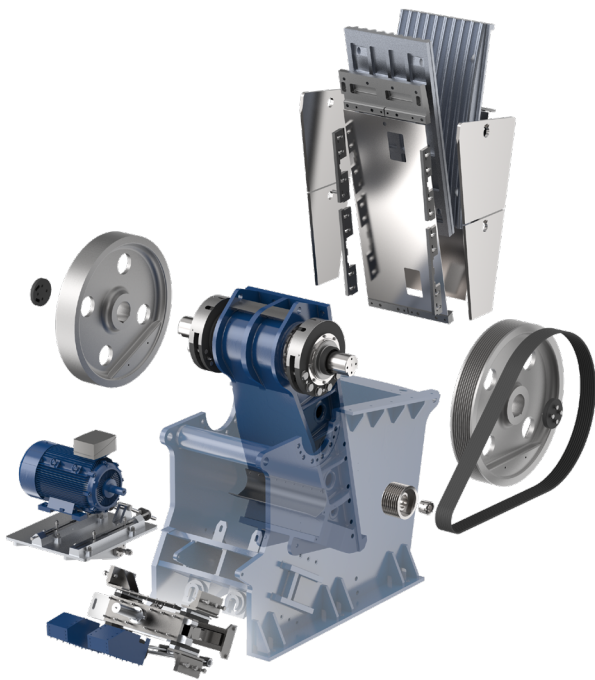

Technical specification

Application data	
Application	Primary crushing
Feed material	Medium hard to hard rock and ore
Capacity ¹	164 – 446 tph

Technical data	
Configuration	Single-toggle jaw crusher
Feed opening ² (A x B)	800 mm x 1,100 mm
Crusher height – inlet	1,900 mm
Crushing jaws	One piece design
Opt. crusher speed	200 – 230 rpm
Gap setting method/ Adjustment range CSS ³	Mechanical, hydraulically assisted / 70 – 225 mm
Drive concept	V-belt
Installed drive motor power ⁴	Opt. 110 KW (up to 132 KW)

Weight and dimensions	
Total weight ⁵	Approx. 28,000 kg
Heaviest piece for erection	Swing jaw assembly 8,5 t
Heaviest piece for maintenance	Fixed jaw 1,9 t
Main dimensions of the crusher (L x W x H)	Approx. 4,350 mm x 2,700 mm x 2,900 mm

1. The actual throughput depends on the feed material characteristics (e.g. bulk density, hardness UCS, feed particle size distribution, moisture content), the desired product size and the selected machine settings (e.g. gap setting CSS).
2. Width A = maximum length between the crushing tools of the oscillating swing jaw and the fixed crushing jaw.
3. CSS = Closed Side Setting (gap setting). The min. CSS depends on the properties of the feed material.
4. Motor rating range applicable for < 1000 m altitude. The nominal motor power selected for the respective application depends on the feed material characteristics, desired product size, actual machine configuration and actual installation height. Due to the generously dimensioned flywheels, smaller electric motors can also be used.
5. Weights indicated do not include base frame, drive motor and tools. Weights may vary depending on the respective machine configuration.

Crushing principle

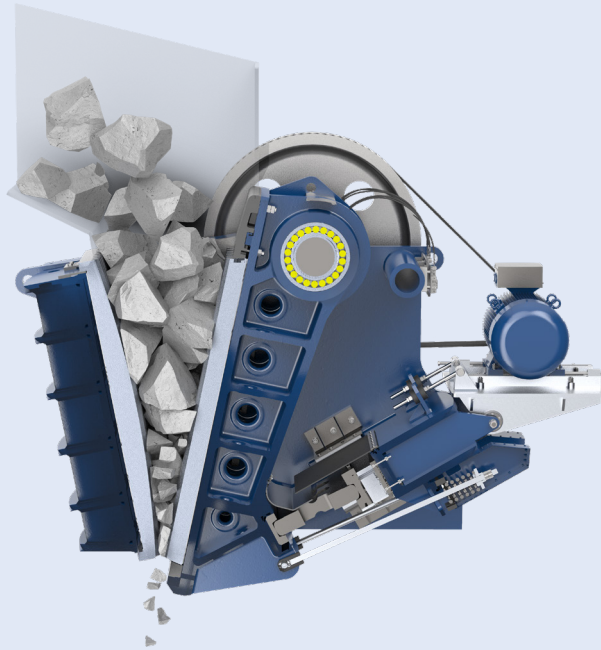

Main dimensions

Side view

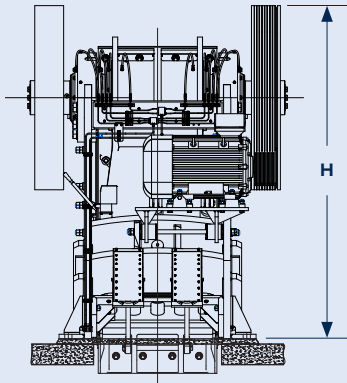

Top view

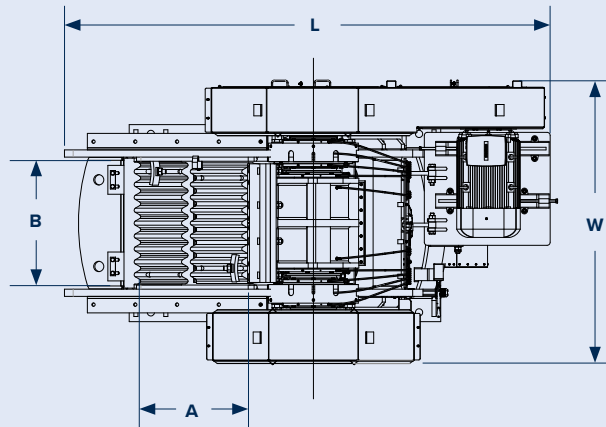

A [mm]	B [mm]	H [mm]	L [mm]	W [mm]
800	1,100	2,900	4,350	2,700

FLSmidth A/S
2500 Valby
Denmark
Tel. +45 3618 1000
info@flsmidth.com

www.flsmidth.com

FLSmidth Inc.
Salt Lake City Operations
Midvale, UT 84047-5559
USA
Tel. +1 801 871 7000
info.sl.c@flsmidth.com

**FLSmidth Mining
Technologies GmbH**
Ennigerloh Operations
59320 Ennigerloh
Germany
Tel. +49 201 828 3000
mining-technologies@flsmidth.com

Copyright © 2023 FLSmidth A/S.
All Rights Reserved. FLSmidth and
FLS are (registered) trademarks of
FLSmidth A/S. This brochure makes
no offers, representations or
warranties (express or implied), and
information and data contained in this
brochure are for general reference
only and may change at any time.